

Hunter®

 **Hydrawise™ Ready**
IRRIGATION CONTROLLERS

Hydrawise Software/App Owner's Manual



hydrawise.com

Table of Contents

Table of Contents	2
Controller - Reboot Controller	4
Controller - Navigating Screens	5
Wireless - Connection Status Messages	6
Controller - Viewing Controller Status	7
Server Status	8
Success	9
Offline	10
Saving Settings	11
Serial Number	11
Controller - Viewing Network Information / Testing Internet Connectivity	11
Controller - Viewing Time and Date	12
Controller - Installing and Wiring	13
Controller - Function Paths	13
Controller - Manual Operation	15
Running a zone manually from the controller	15
Controller - Factory Default	16
Controller - Serial Number Location	18
Controller - Blank Display	19
Account - Remote Feature	20
Account - Location	23
Account - Language	25
Account - Controller Status	27
Account - Linking Controller	28
Account - Adding a Controller	29
Account - Controller Weather Stations	32
Account - Water Triggers	35
Smart (ET) Watering	37
Account - Running Zone(s) Manually	40
Manual Single Station	40
Accounts - Reports	42
Account - Controller Configuration	47
Account - Account Details	50
Account - Viewing Controllers	54
Account - Assigning Images on Mobile	56
Account - System Shut Off (Winterization)	59
Account - Delete Controller	62
Account - Virtual Weather Station	66
Account - Units of Measurement	69
Account - Adding a Contractor	70
Account - Account Name Edit	72
Account - Rename Controller	73
Account - Add User/Files	75
Add User	75
Account - Setting Delay	78

Account - Exporting Reports	80
Account - Moving Serial Number	81
Account - Resetting Password	83
Account - Not Receiving Hydrowise Activation Emails	84
Configuring - Several Watering Lengths One Zone	85
Configuring - Trigger "Water More Often When Hot"	88
Configuring - Trigger "Water Longer When Hot"	93
Setting Trigger	94
Smart Watering - Quick Reference	96
Smart Watering - Adjustment and Changes	97
Offline Mode - Accessing Offline Mode	101
Offline Mode - Run the Setup Wizard	104
Offline Mode - Sensors	106
Offline Mode - Turning Off Start Times	108
Offline Mode - Seasonal Adjust	110
Account - API Information	112
Smart Voice Device - Amazon Alexa	113
Home Automation - Control4	117
HPC - Upgrading Pro-C	117
HCC - Valve Wiring	118
HCC - AC Wiring	119
HPC- WRCLIK and HC Flow Meter	123
Flow Meter - Configuration	124
Flow Meter - Quick Start Guide	127
Flow Meter - Installation Tips	127
Flow Meter - Specifications	129
Flow Meter - Reading Meter	130
Flow Meter - Testing Meter	131
Flow Meter - Custom Flow Sensor Configuration	133
Flow Meter - Winterization	134
Sensors and Flow Meter - Configuration	135
Flow Meters	136
Rain/Moisture Sensors	136
Wiring	137
Sensors - Clik Sensor Status	141
Normally Closed (Default Setup) All Hunter CLIK Sensors	141
Sensors - Installing Personal Weather Station	142
Master Valve - Configuration	143
How does it work?	143
Master Valve - HC	144
Master Valve - PRO-HC	144
Master Valve - HPC-FP (Panel for PC-400 controller)	145
Valve - Wire Distance	146

Controller - Reboot Controller

Please follow the steps below to perform a reboot on your controller. This can help reestablish WiFi if you are having communication issues. The reboot will not erase any settings in your controller.

1. From the home screen, tap on **Settings**.
2. Next, press **Config**.
3. Press **Reboot Controller**.

STEP 1



STEP 2

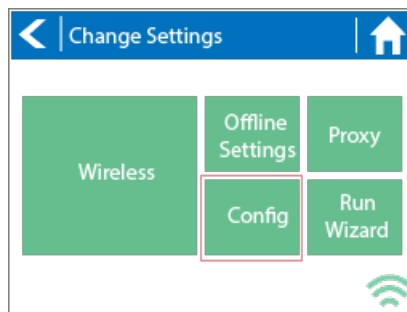

STEP 3

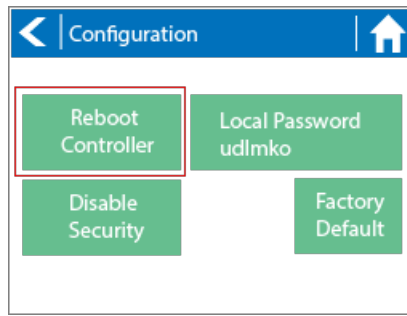

Controller - Navigating Screens

The controller features a full color touchscreen making navigation easy.

The Home screen, shown below, has 3 buttons allowing you to view and run your irrigation zones, change controller settings or view status information.



- 1 Touch to view all zones
- 2 Touch to change controller settings
- 3 Touch to view controller status information

Each screen (except for the home screen) has two buttons at the top of the page allow you to quickly navigate to the Home screen or the previous screen.



- 1 Go to previous screen (changes not saved)
- 2 Go to Home screen (changes not saved)
- 3 GREEN items indicate settings which can be changed
- 4 GREY items indicate status information

All items on each screen are color coded to indicate which screen elements are buttons and which screen elements indicate status information.

GREEN screen items indicate settings that can be changed. If you touch on the GREEN color item then you'll be able to change that setting.

GREY colored items indicate status information. Touching on these has no effect.

If you're entering information into the controller and use the Home or Back buttons then your changes on that screen will not be changed.

Wireless - Connection Status Messages

The controller will show different status messages while connecting to your wireless router.

Looking for Wireless	Controller is currently scanning for local wireless networks.
Connecting to	Controller is currently trying to connect to your wireless router.
Waiting for IP	Controller has connected to your wireless router and is waiting for your wireless router to give it an IP address. Your wireless router must be configured as a DHCP server.
Connected	Controller has successfully connected to your wireless router.
Local Connection Only	Controller is acting as a local wireless router.

Troubleshooting Wireless Connection Issues

After entering your wireless settings, the controller will connect to your access point. The connection process takes about 30 seconds.

Upon successful connection the wireless status will show **Connected**.

If your controller fails to connect to your wireless router check the following:

- Your password is entered It is case sensitive and must be at least 8 characters long.
- Check that the wireless security types match between the controller and your wireless router. Hydrowise recommends use of WPA2 security between the controller and your wireless router.
- We have WiFi specifications here: [WiFi Specs](#) ^[1]

Controller - Viewing Controller Status

From the Home screen, navigate to the Controller Status by pressing Status > Controller Status.

The controller status screen shows your controller's connection to Hydrawise servers for synchronizing schedule and weather information.

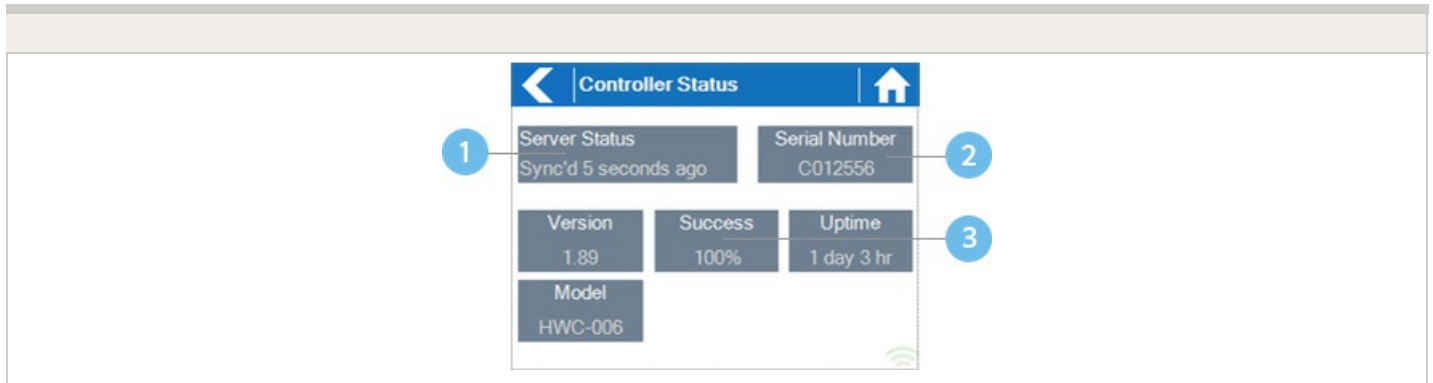

- 1 Status of Connection to Hydrawise Servers
- 2 Your Serial Number. Used to link your controller to your account
- 3 Connection to Hydrawise Success Rate

Server Status

A successful connection to the Hydrawise servers is indicated by **Sync'd** as the Server Status.

SERVER STATUS MESSAGES

Message	Description
OK - updated xxx seconds ago	The controller is connected to Hydrawise and last got a configuration update xxx seconds ago. This is the normal state.
Wireless Down	Wireless is not connected
OK - Updating certificates	The controller is doing an initial upgrade from version 2.x to 3.x software. You should only see this once, if the controller is continually showing this then there is a problem - please contact Anthony with a video of the problem.

OK - Downloading Software	The controller is doing a firmware upgrade. During this period no configuration changes will be processed by the controller.
Connecting in xxx seconds	The controller is not connected and is waiting xxx seconds before attempting to reconnect to the internet. When a connection fails we do not try to reconnect immediately - there is an escalating delay between 5 seconds the 60 minutes (worst case after 33 unsuccessful connections). There is a “Reconnect Now” button on the Controller Status screen to force a reconnection immediately if you’re in front of the controller.
Connecting to the Internet	The controller is attempting to connect to the internet
Connecting to Hydrawise	Controller has connected to the internet and is now connecting to the Hydrawise servers
OK - subscribing to updates	Controller has connected to Hydrawise and is getting its configuration
OK - processing cloud update	Controller is connected to Hydrawise and is processing a configuration change
Updating Wi-Fi firmware	The controller is updating the Wi-Fi firmware to 19.5.4. During this period no configuration changes will be processed by the controller.
Updating Pro-C adapter	The controller is updating the Pro-C adapter software. During this period no configuration changes will be processed by the controller.

Success

Success percentage - this is the percentage of time the controller has been connected to Hydrowise. We measure this over a 6-hour time frame. 100% means it was always connected, 80% means that for 20% of the time it was not connected.

A low success percentage will indicate a poor wireless connection between the controller and your access point.

To improve your wireless signal strength you could try the following –

- Move the controller closer to your wireless router.
- Remove any obstacles in a direct line of sight between the controller and your wireless router such as metal items (metal is an extremely good isolator for WiFi signals).
- Move your wireless router closer to the controller.
- Install a higher gain antenna on your wireless router.
- Use Ethernet to a location closer to the controller and install a new wireless router.
- Consider a WiFi repeater/extender between your wireless router and the Hydrowise controller to boost the signal strength.
- Consider moving the controller away from potential sources of interference, including microwave ovens, nearby base stations using adjacent channels or cordless telephones operating in the 2.4GHz range (you could also change the channel your phone uses).

Note that the Hydrowise unit is designed to work in poor wireless environments. However, if you wish to manually run or stop a zone and the wireless signal is down then these actions will fail.

Offline

If the controller loses internet for more than 24 hours you'll receive a notification email.

The controller will go into an offline mode. In offline mode, your controller won't be able to access local weather conditions such as rainfall or evaporation and will revert to a pre-defined program.

- For Smart Watering zones, the controller will adjust each zone's watering length based on your offline watering budget and will water at each zone's configured peak watering frequency.
- For Time Based Watering zones, the controller will adjust each zone's watering length based on your offline watering budget and will water at each zone's configured watering frequency.
- For more information on Smart and Time Based Watering, see "[Configuring Irrigation Zones](#)" ^[2].
- Note that Cycle & Soak is not supported in Offline Mode and each zone will water for its full watering length without pausing.

- The controller will only water at your configured Program Start Times.

Saving Settings

The controller does not need a battery, all settings are saved in a non-volatile RAM (memory).

Serial Number

The serial number is used to link your actual controller with your Hydrowise account. This number is also printed on the rear of the controller.

Controller - Viewing Network Information / Testing Internet Connectivity

From the Home screen navigate to the Network Status by pressing Status > Controller Status.

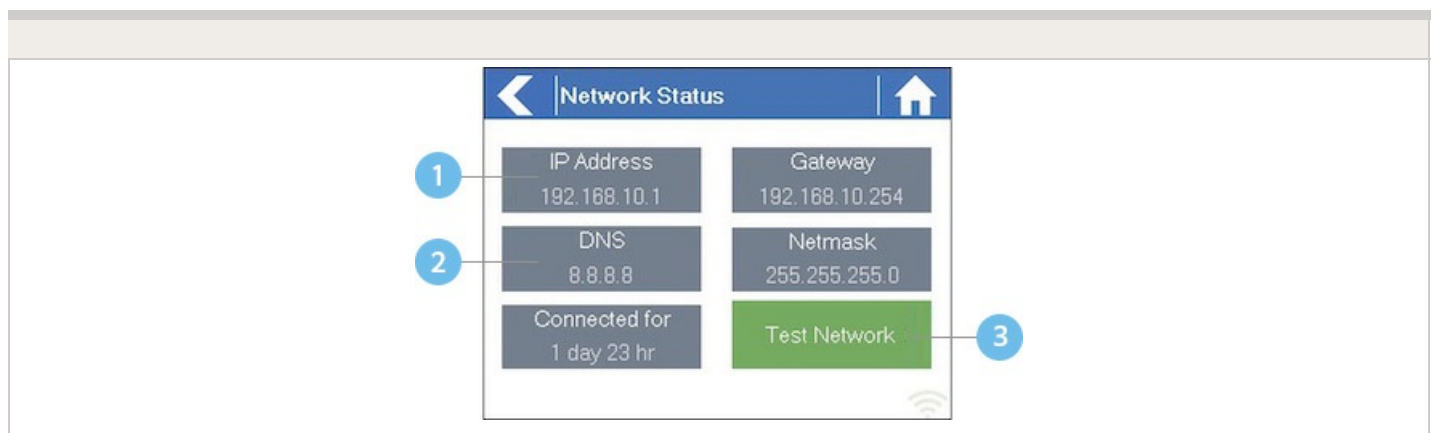

- 1 IP Address (set by your wireless router)

2 DNS Address (set by your wireless router)

3 Network Test Button

All settings on this page are provided to the controller by your wireless router when it first connects via a protocol, known as DHCP. If any of these settings appear incorrect please change them in your wireless router.

Once the controller has successfully connected to your wireless router the Test Network button can be used to test network connectivity for troubleshooting purposes. The network test will verify connectivity to 4 destinations –

Test Network

Message Description **Checking WiFi** Performs a ping test to the Gateway address listed in the Network Status screen. If this test fails, check that you don't have MAC address filtering enabled on your router. **Checking DNS** Performs a ping test to the DNS address listed in the Network Status screen. If this test fails, check that the DNS address is correct – if it is wrong then correct the DNS address under DHCP Settings on your wireless router. It is possible that this test may fail if the DNS server doesn't accept ping requests which do not indicate an issue. **Checking Internet** Performs a ping test to the Google server at IP address 8.8.8.8. This is a well-known server which accepts ping requests on the internet. If this test fails then it indicates an issue with the internet configuration of your wireless router. **Checking Hydrowse** Performs a ping test to the Hydrowse servers. If this test fails then it may indicate an issue with the internet configuration of your wireless router.

Controller - Viewing Time and Date

Time and date settings are synchronized with the settings that you configure in the Hydrowse app. The timezone is set based on the location you entered during the app wizard.

Time and Date

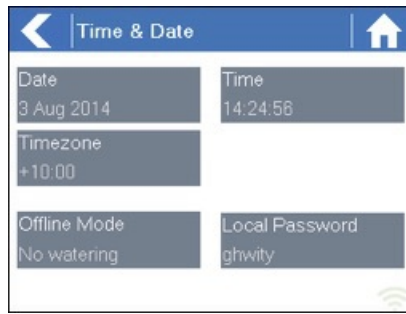

If your controller is running as a stand-alone controller (WiFi is disabled) then the date, time and time zone will be shown on a GREEN background can be changed.

Controller - Installing and Wiring

You can also find the instructions included with the controller on our [Quick start Guides](#) ^[3] page.

For instructions on installing your residential controller, please visit our basic wiring setup page for PROHC and HC models [here](#) ^[4].

NOTE: Once you've wired and installed your controller, please see [Configuring Your Controller](#) ^[5] for instructions on how to connect to your Wi-Fi.

Controller - Function Paths

Below is a list of function paths for use with the controller interface in both online mode and

offline mode.

ONLINE MODE

Change Wi-Fi/Check Status: Home>Settings>Wireless>Select a Setting to Modify

Controller Status: Home>Status>Controller Status

Program Expander: Home>Status>Expansion Modules

Manually Run Zone(s): Home>Zones>Select Zone> Run>Enter Time>OK

Model: Home>Status>Controller Status

Network Status: Home>Status>Network

Reboot Controller: Home>Settings>Config>Reboot Controller

Reset Controller: Home>Settings>Config>Factory Default

Run Wizard: Home>Settings>Run Wizard

Sensor Status: Home>Status>Sensor

Serial Number: Home>Status>Controller Status

Server Status: Home>Status>Controller Status

Test Network: Home>Status>Network>Test Network

Test Zone: Home>Status>Zone Tester

Time and Date: Home>Status>Time

Version Number: Home>Status>Controller Status

Zone Status: Home>Zones>Select Zone

OFFLINE MODE

(Note: Changes can be done in offline status only when Wi-Fi is disabled.)

Adjust Time: Home>Settings>Offline Status>Time

Disable Wi-Fi: Home>Settings>Offline Status>Disable Wi-Fi

Program Expander/Check Status: Home>Settings>Offline Status>Expansion Modules

Program Sensor/Check Status: Home>Settings>Offline Status>Sensors

Program Start Times: Home>Settings>Offline Status>Program Start Times

Set Seasonal Adjust: Home>Settings>Offline Status>Seasonal Adjust

Controller - Manual Operation

You can run an irrigation zone on demand from the Hydrowise unit prior to having the system connected to wifi.

Running a zone manually from the controller

From the **Home** screen, navigate to the **Zone Summary** screen by pressing **Zones**.

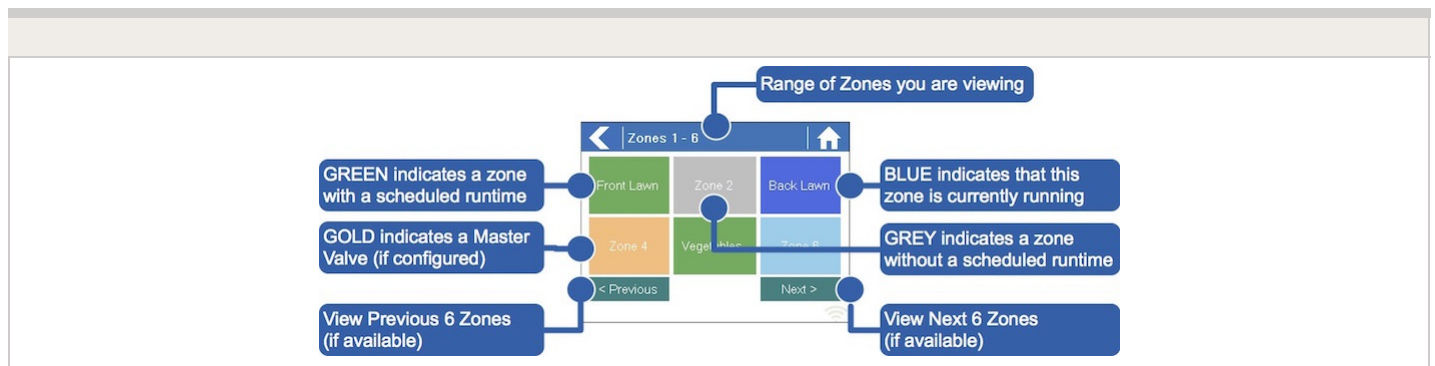

The Zone Summary screen shows the status of six zones at a time. To view the next or previous group of zones, use the **Next** and **Previous** buttons. The current range of zones that you are viewing is indicated at the top of the screen.

From the Zone Summary screen, touch the zone you wish to view.

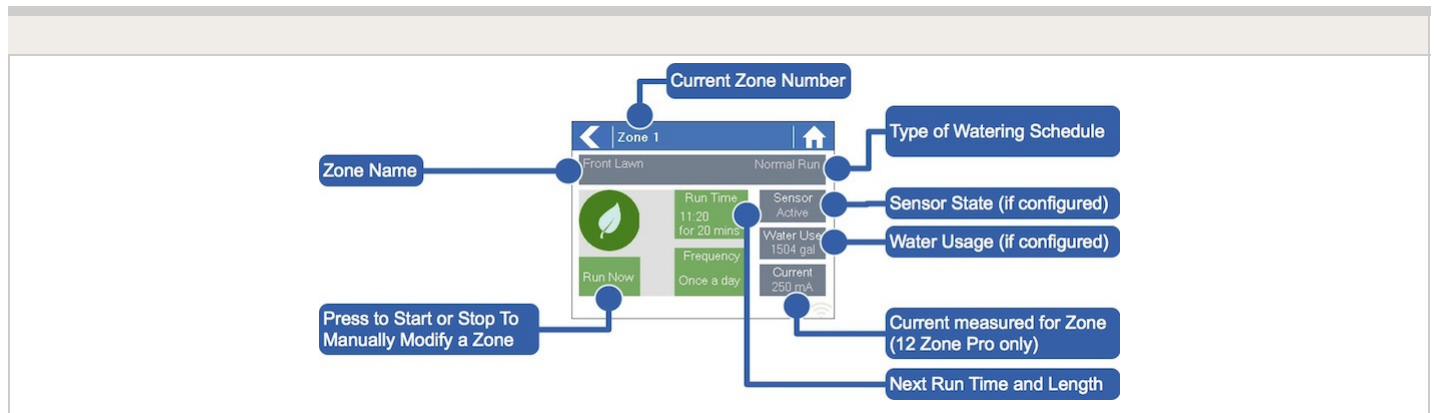

From the Zone Status screen, you can manually start a zone using the **Run Now** button. When started, the zone will run for the zone's default configured run length. This can be overridden by clicking on **Run Time** prior to manually starting the zone.

When a zone is running, the **Run Now** button will change to **Stop**. This allows you to stop a running zone.

Controller - Factory Default

Please follow the steps below to perform a factory reset on your controller. When the controller goes back online, the settings in the software will sync back into controller.

1. From the home screen, tap on **Settings**.
2. Next, press **Config**.
3. Press **Factory Default**.
4. Finally, press the **Erase Config**.

STEP 1

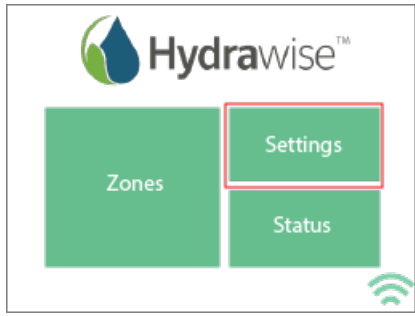

STEP 2

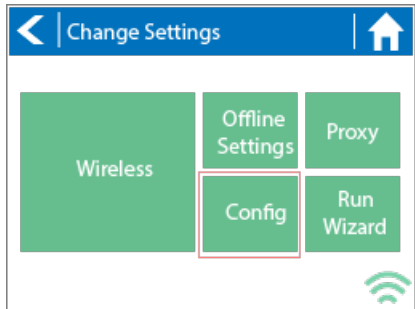

STEP 3

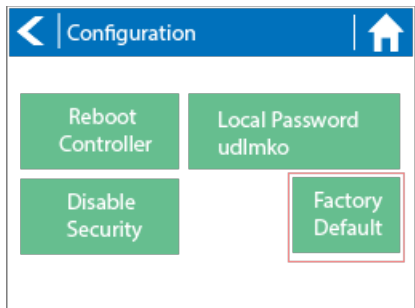

STEP 4

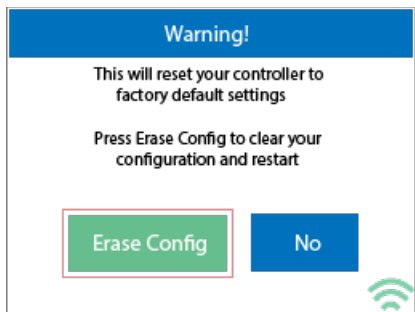

Congratulations, you have now successfully factory reset your controller. The controller is now ready for fresh configuration settings, either manually or automatically through synchronization with your Hydrowise account.

To link your controller to your account, refer to [Linking Your Controller to Your Account](#) ⁽⁶⁾.

Controller - Serial Number Location

Your controller's serial number is found on the rear of your controller or on the controller's touch screen.

To access the serial number on the touch screen, follow these steps:

1. From the Home screen, click **Status**.
2. Then click **Controller Status**.
3. The serial number is shown on this screen. Note: The serial number contains only letters **a through f** and numbers **0 through 9**.

STEP 1

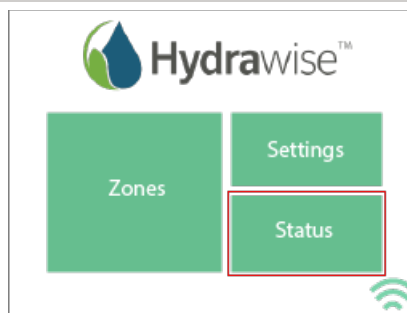

STEP 2

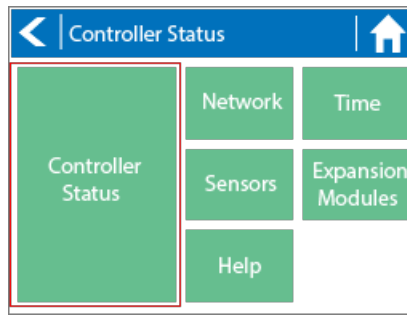

STEP 3

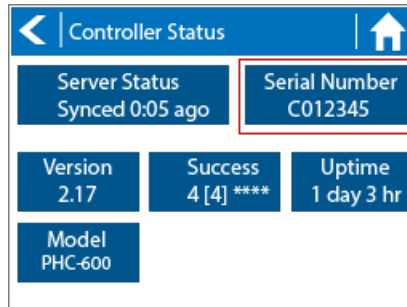

To link your controller to your account, please refer to this article [Linking a Controller to My Account](#) [7].

Controller - Blank Display

First, make sure there is power to the controller's outlet. Use a test lamp or any other 110VAC device to determine if there is voltage at the outlet. If there isn't power, or if you have a controller that is hard wired, check the circuit breaker at the main breaker box.

Caution: High voltage testing on the transformers primary power side should only be done by a professional electrician or irrigation contractor.

Checking Transformer Voltage

If you have power at the outlet, the next thing to check is the transformer output. Use a voltmeter to check the voltage either on the two transformer wires or at the two AC screw terminals on the controller. The transformer

should have an output in the range of 24VAC to 28VAC.

If the wall outlet has 110VAC and the transformer has no voltage output, you need to replace the transformer.

Cycle Controller Power

If you have voltage at both the wall outlet and the transformer output and you still have a blank display, try cycling the power on the controller. To cycle the power on the controller:

1. Remove power by unplugging the transformer from the wall outlet or by turning off the circuit at the breaker box.
2. Wait a few minutes.
3. Plug the controller transformer back into the electrical receptacle, or turn the breaker panel switch back on.

Note: If this doesn't restore the display, the controller will need to be replaced.

Account - Remote Feature

Hydrawise offers a "**Remote Feature**" that provides four styles of Manual Watering. This feature allows you to do any of the following.

Please view the steps and screenshots below to access and use this feature:

1. **Single Zone** – Allows you to manually start a single zone for the scheduled time or a time you manually change
2. **All Zones** – Runs all zones for the normally scheduled time or a time you manually change
3. **Programs** – Manually select either all or some zones to start
4. **Zone Tester and Winterization Tool** – For contractor system testing and winterization

Click on "**Remote Icon**" from the home dashboard. Then select one of four options to start a zone.

Dashboard View

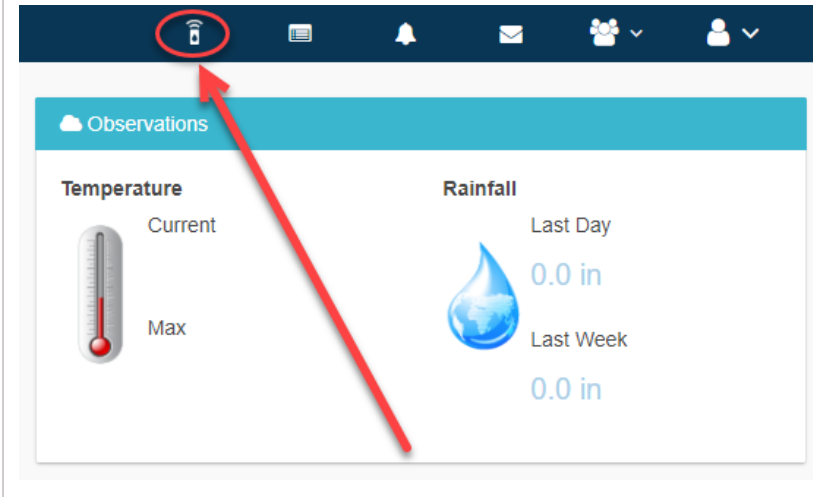

The screenshot shows a dashboard interface. At the top is a dark blue navigation bar with several icons: a Wi-Fi signal icon (circled in red with a red arrow pointing to it), a calendar icon, a bell icon, an envelope icon, a group of people icon, and a user profile icon. Below the navigation bar is a teal header labeled "Observations". The main content area is divided into two columns. The left column is titled "Temperature" and features a thermometer icon. It shows "Current" and "Max" values. The right column is titled "Rainfall" and features a blue water drop icon. It shows "Last Day" and "Last Week" values, both of which are "0.0 in".

Option 1

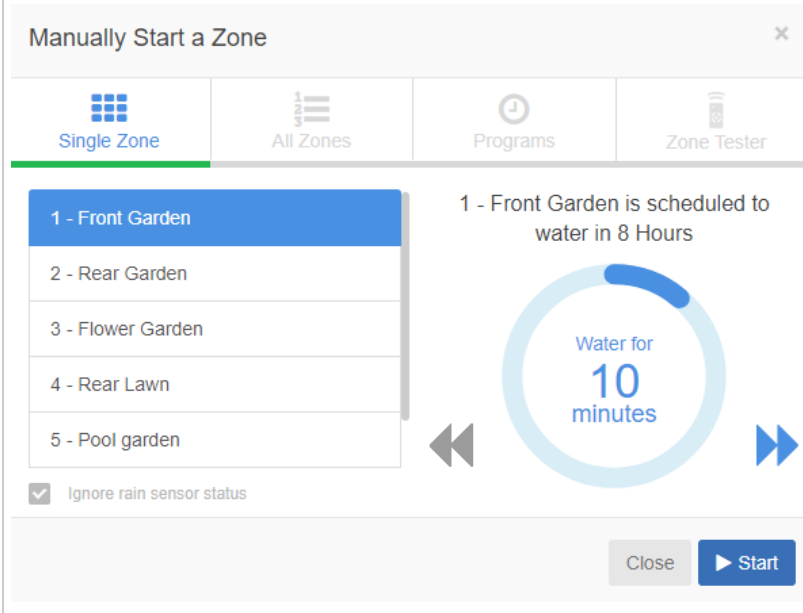

The screenshot shows a "Manually Start a Zone" dialog box. At the top, there are four tabs: "Single Zone" (selected), "All Zones", "Programs", and "Zone Tester". Below the tabs is a list of zones: "1 - Front Garden", "2 - Rear Garden", "3 - Flower Garden", "4 - Rear Lawn", and "5 - Pool garden". The "1 - Front Garden" zone is selected. To the right of the list, a message states: "1 - Front Garden is scheduled to water in 8 Hours". Below this message is a circular progress indicator with a blue arc and the text "Water for 10 minutes". There are left and right arrow buttons on either side of the circle. At the bottom left, there is a checked checkbox labeled "Ignore rain sensor status". At the bottom right, there are "Close" and "Start" buttons.

Option 2



The screenshot shows a large, empty white rectangular area, likely representing a second option or a placeholder for content.

Manually Start a Zone

Single Zone | All Zones | Programs | Zone Tester

- 1 - Front Garden
- 2 - Rear Garden
- 3 - Flower Garden
- 4 - Rear Lawn
- 5 - Pool garden

Run for each zone's normal run time

Water for 10 minutes

Ignore rain sensor status

Close | Run Now

Option 3

Manually Start a Zone

Single Zone | All Zones | Programs | Zone Tester

4:47pm - All Zones

Run for each zone's normal run time

Ignore rain sensor status

Close | Run Now

Option 4

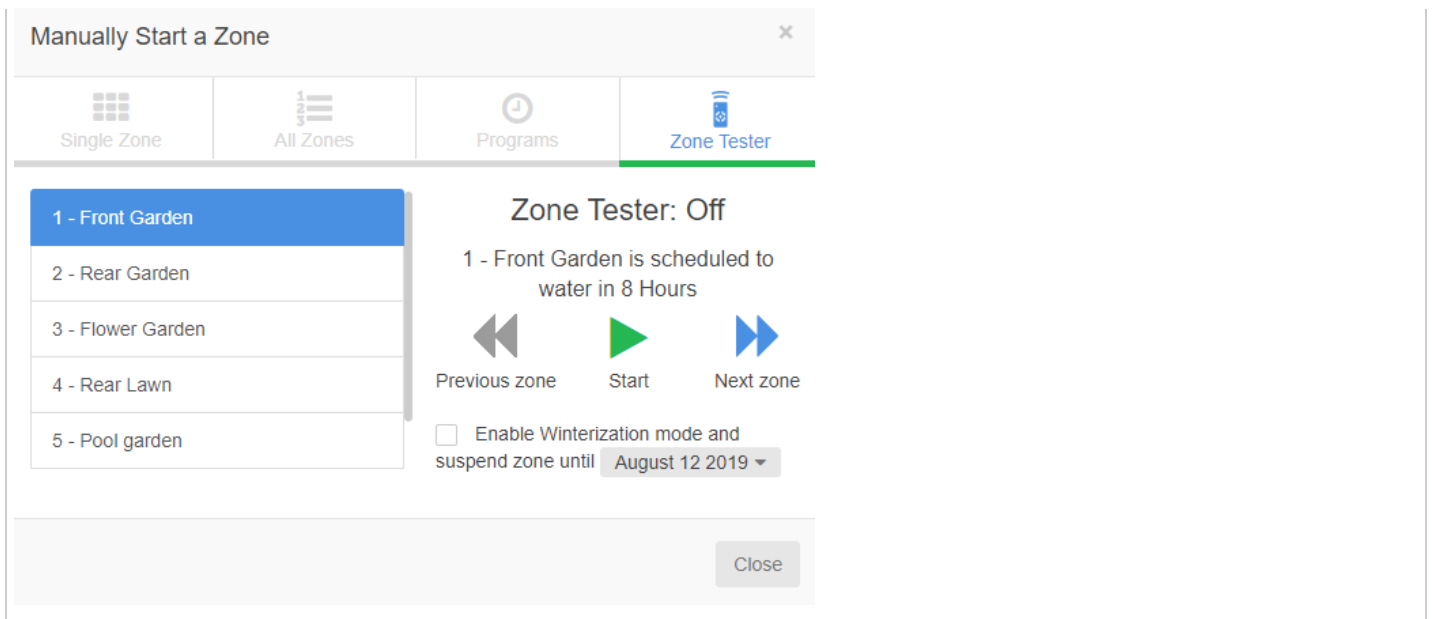

Account - Location

The location is synchronized after the settings are configured in the Hydrowise app. The time zone and forecast are automatically set when the **location** is entered during the app set up wizard process. In the event this setup needs to be changed or updated, we recommend editing the setting in the application under the **Weather station** tab.

Please view the steps and screenshots to set the weather station location:

1. Click on the "**Controller Settings**" tab on the left hand side.
2. Select "**Weather Stations.**"
3. Enter the "**complete street address.**"
4. Regional setting will "**automatically**" be updated to the correct timezone.

STEP 1

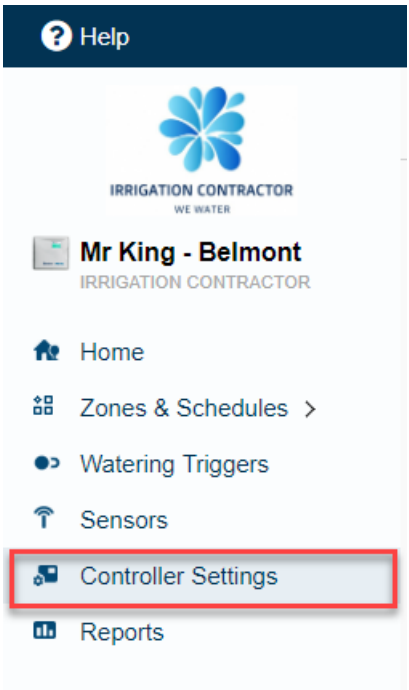

STEP 2

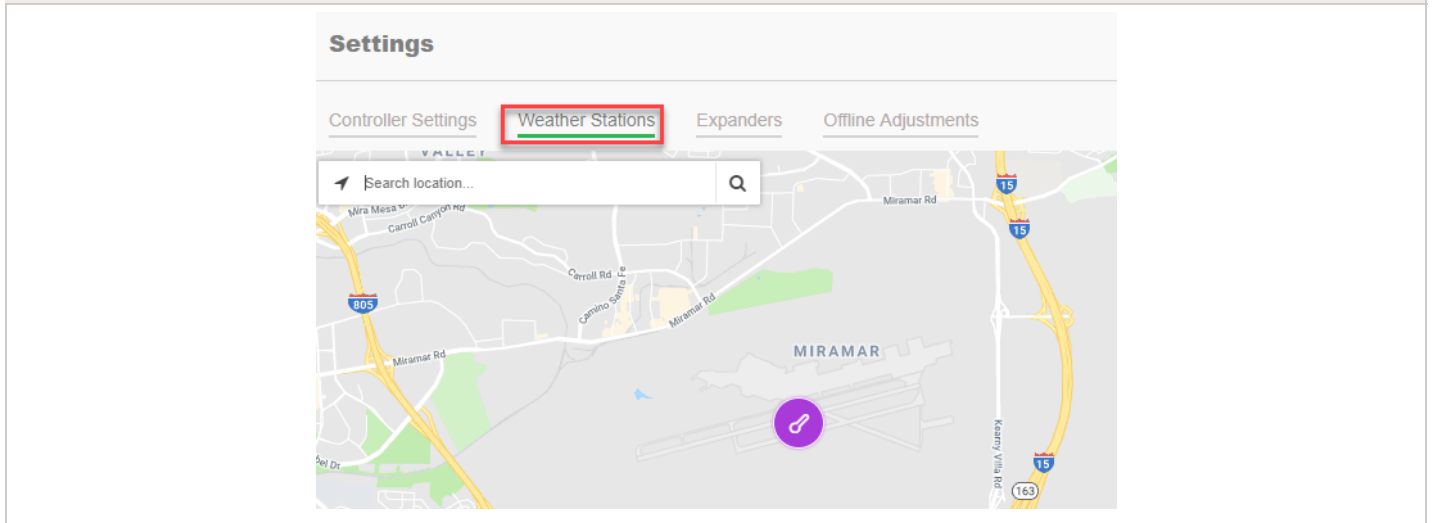

STEP 3

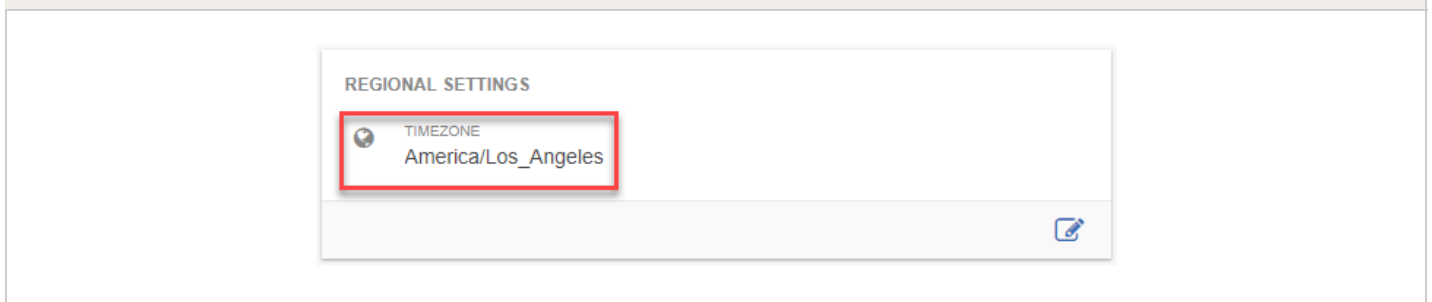

NOTE: If your controller is running in offline mode (WiFi is disabled) then the date, time and time zone will be shown on a GREEN background can be changed.

Account - Language

For information on changing the language on your account, please view the steps and screenshots to access this feature:

1. Click **"Account Details"** under the settings tab on the upper right.
2. Click the  icon in the user settings box.
3. Choose the **"language"** and select **"ok."**

STEP 1

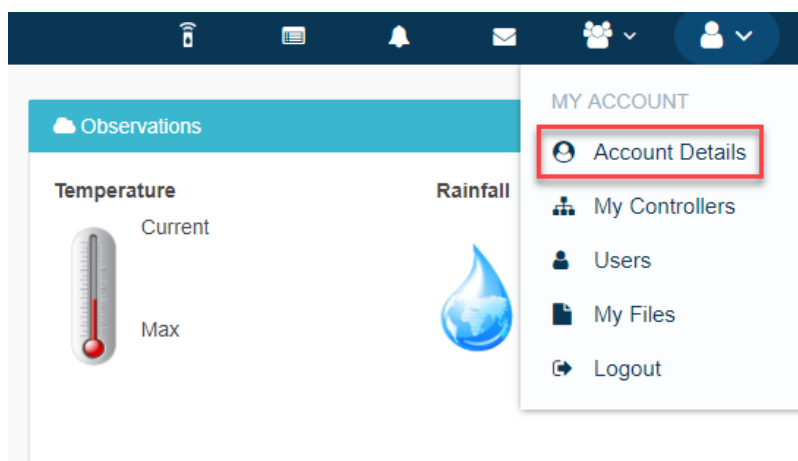



STEP 2

USER SETTINGS

 UNITS OF MEASUREMENT
Celsius & Millimeters

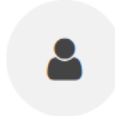
 LANGUAGE
English

Hydrawise Contractor
contractor@hydrawise.com



STEP 3

Edit User ×

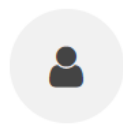
[Change picture](#)

Name

Email Address

Units of Measurement

Language

Account - Controller Status

The message options below will display on the home dashboard under "**controller status**" when logged into you Hydrowise account. See example of a good wifi connection below:

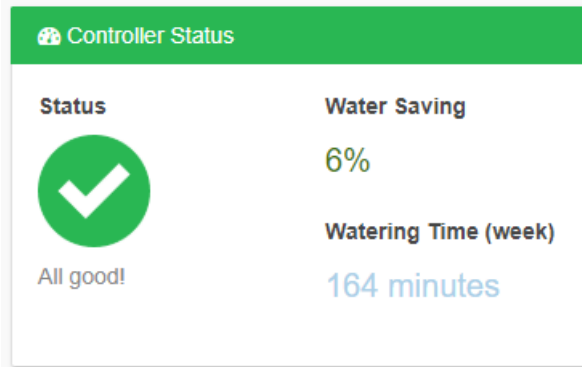

Controller Status	
Not Connected	The controller is not connected to Hydrowise. We detect this within about 7 minutes so this would be a connectivity problem.
All Good	The controller is connected to Hydrowise and the controller has the latest config.
Waiting for Confirmation	The controller is connected to Hydrowise but there is a difference between the app settings and the controller settings. This icon is normal to see just after a configuration change (including changes from the dashboard such as manual start/stop) is made but should only be visible for a few seconds.
Out of Sync	The controller is connected to Hydrowise and there is a difference between the cloud configuration and what the controller has reported and it has been longer than 60 seconds since the change happened. This is not a normal state however you will see this if the customer has configured more than 4 program start times per zone or 4 global start times due to controller memory.

Note: That you can have more than the recommended start times which will all run as long as the controller remains online, it will just say out of sync for the reasons above. If the controller goes offline it will only run the first 4 individual start times and the first 4 global start times.

Account - Linking Controller

After you receive your Hydrowise irrigation controller, you will need to link it to your Hydrowise account.

There are two locations where you can link your controller to your account:

- During the setup wizard (optional)
- From the controller **Dashboard**

NOTE: You only need to link your controller to your account once. If you provided a serial number when going through the setup wizard, you've successfully linked your controller to your account and you can ignore these instructions.

To link your controller through your account Dashboard, follow these steps:

1. [Log in to your account](#) [8].
2. On the Dashboard, click on the **Settings icon** located on the blue Watering Schedule bar. Then click the **Link to controller...** button.
3. Enter your controller's **serial number**. The eight-character serial number is found on the side of the unit. The serial number is not case-sensitive.

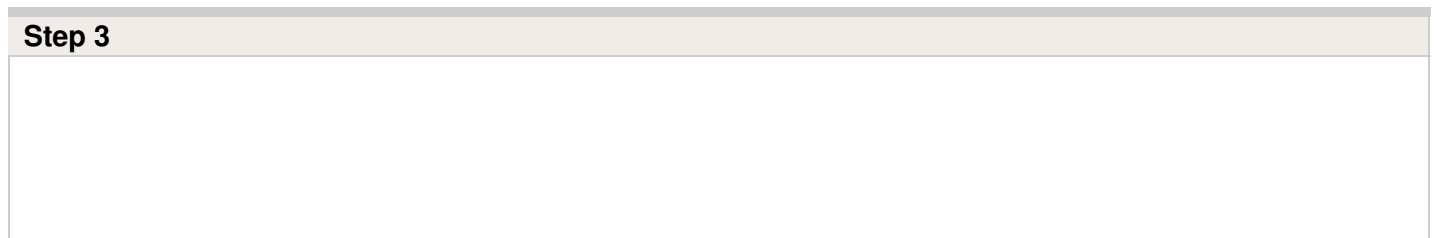
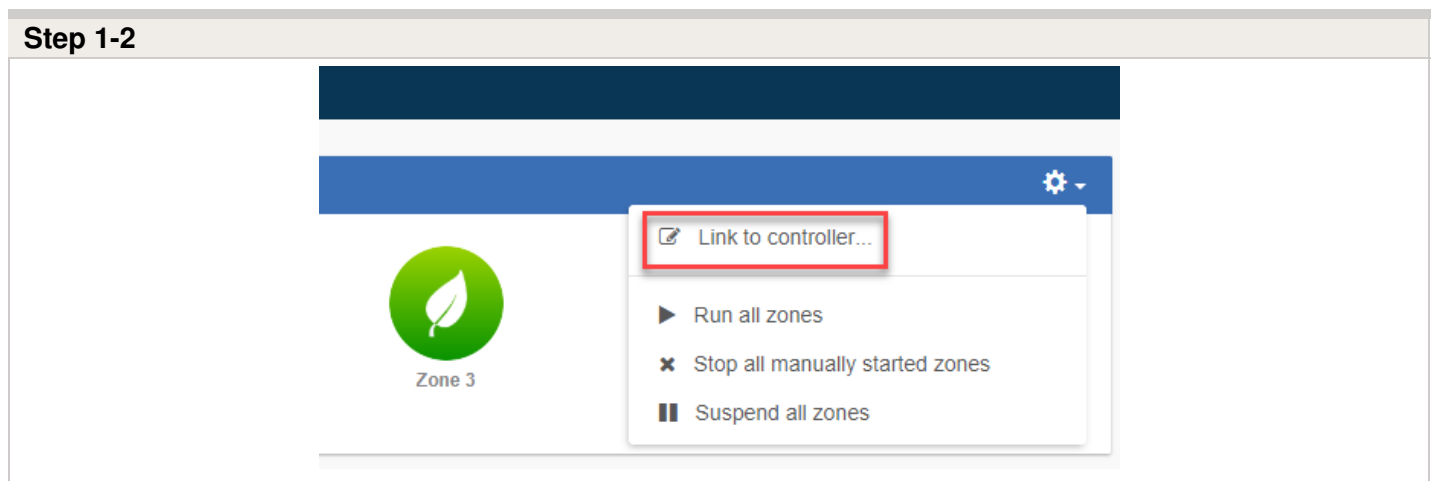

Link to controller
✕



To link your Hunter controller hardware with this account please enter your controller's serial number.

You can find the serial number on the rear of the unit or on the *Controller Status* screen.

Once this account and your controller are linked, your Hunter controller will start watering based on your watering schedules.

Cancel
Link to controller

Once you've entered the serial number, your controller will automatically download your settings and begin watering based on your watering schedules.

Account - Adding a Controller

For information on adding a controller to your account on the PC, please see the steps and screenshots below:

1. Select the **"My Account"** drop down on the upper right hand side on the dashboard.
2. Select **"My Controllers."**
3. Click the **+** button in the my controllers section.
4. Add the new controller by inputting the name, serial number, location and model.
5. Click **"create"**.

Plan	Max Controllers
Home Plan	3 Controllers
Enthusiast Plan	5 Controllers

STEPS 1-2

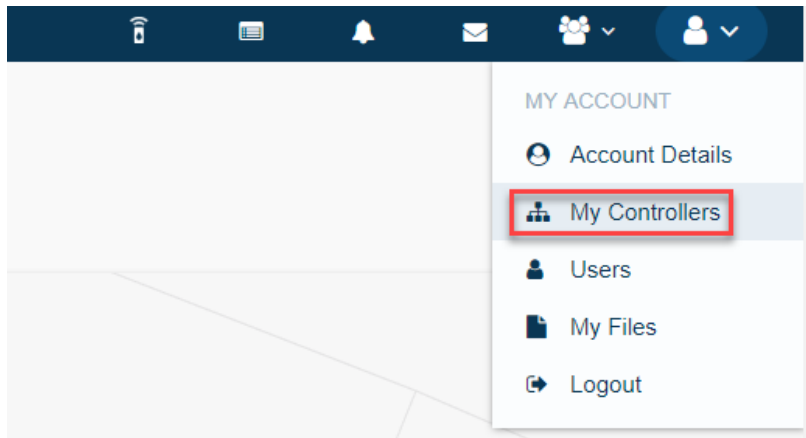

STEP 3

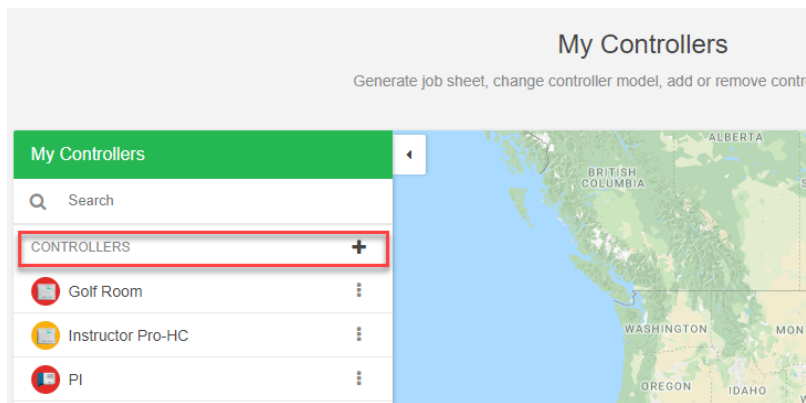

STEP 4

Add New Controller ✕

Controller name

Enter the name of the new controller

Serial number

If you know the serial number of the controller enter it here, otherwise leave it blank

Location

Please enter your location

Cancel < Prev Next > Create

STEP 5

Add New Controller ✕

Controller model

Please choose your controller model



HC
6 or 12 Zone Controller

6 Zones

12 Zones



Pro HC Indoor/Outdoor
6, 12 or 24 Zone Outdoor Controller

6 Stations

12 Stations

24 Stations



HPC
Pro C WiFi Facepanel Upgrade

Up to 16 Stations

Cancel < Prev Next > Create

Account - Controller Weather Stations

Setting your location allows your Hydrowise controller to adjust watering based on your local weather conditions.

IMPORTANT: Your weather forecasts and local weather stations are based upon your location so it is important to configure your location correctly in the application.

The chart below has the stations available based on the plan you have on your account.

Station Options		
Personal Weather Stations	Up to five can be selected on the Enthusiast plan	<p>Weather Stations Your Enthusiast plan allows you to select up to 5 Weather Stations updated hourly. If you select multiple weather stations then your weather station readings are averaged out to give a higher degree of rainfall accuracy.</p>  <p>Closest Station 0.00 mi 1943 Diamond St, San Marcos, CA 92078, USA</p> <p>27 Stations</p> <ul style="list-style-type: none"> 22 Personal Weather Stations 4 Free Airport Weather Stations 1 Free Virtual Weather Station <p><input type="checkbox"/> Show weather stations not reporting temperature and rainfall</p>
Airport Weather Stations	Up to one can be selected on a free Home Plan	
Virtual Weather Stations	Up to one can be selected on a free Home Plan	

Please view the steps and screenshots to access this feature:

1. From the home menu on the left hand side of the screen, select **Controller Settings**.

2. Select "**Weather stations.**"
3. Enter the location of your controller with full street address and click **Click arrow icon** to update.
4. Click on the most relevant weather station(s). To start using a station, press the **Select** button.

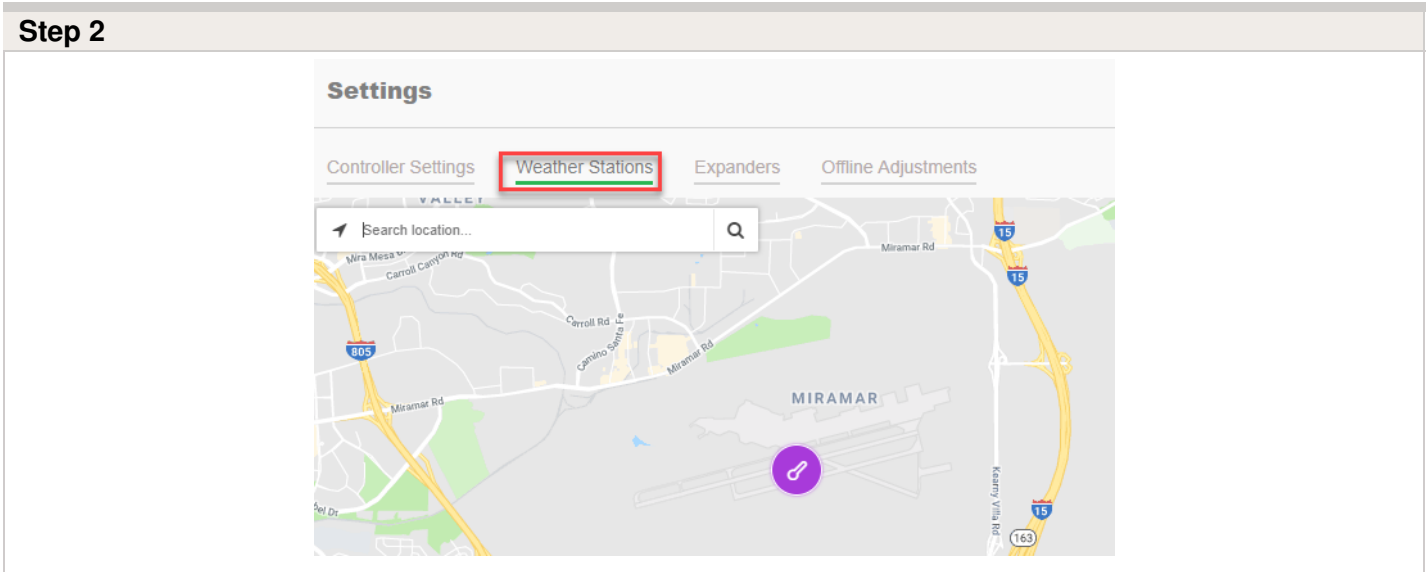
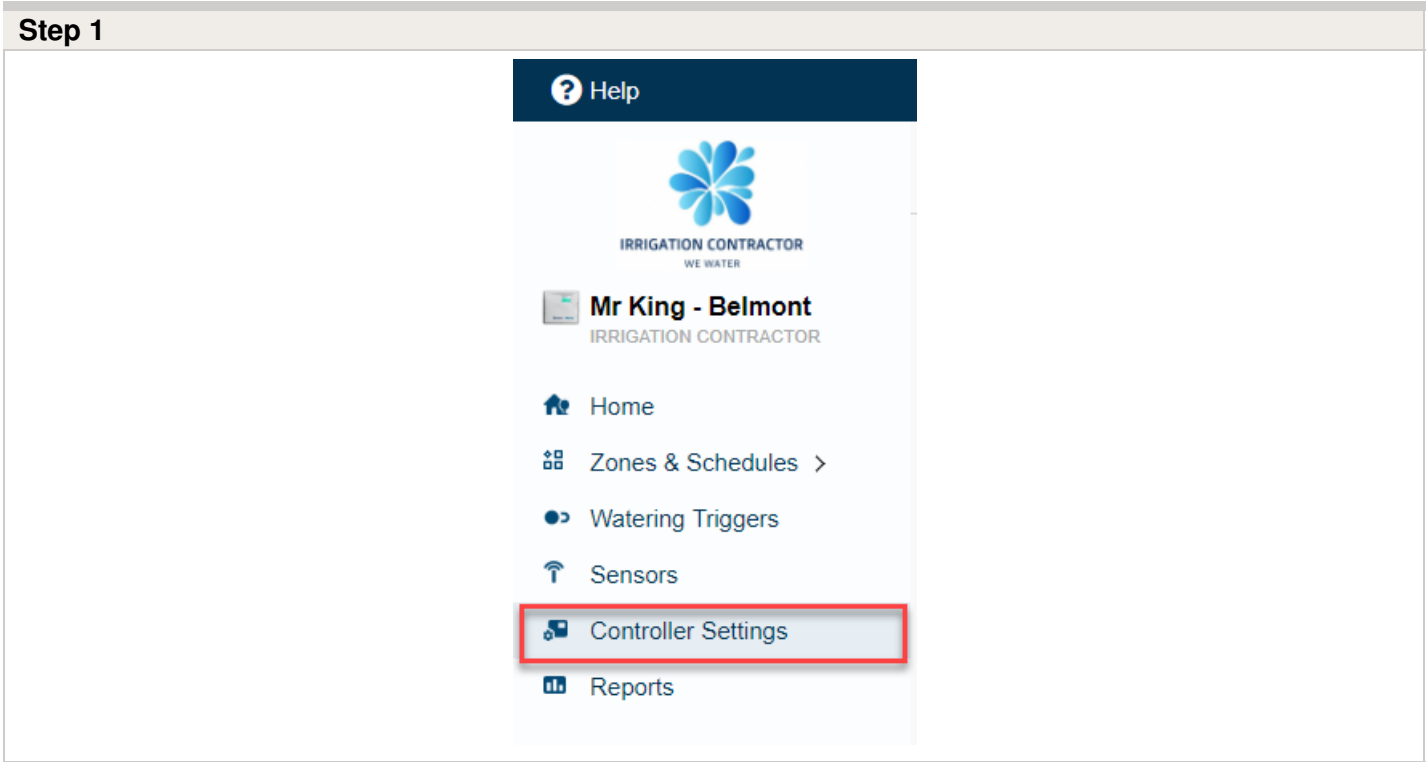

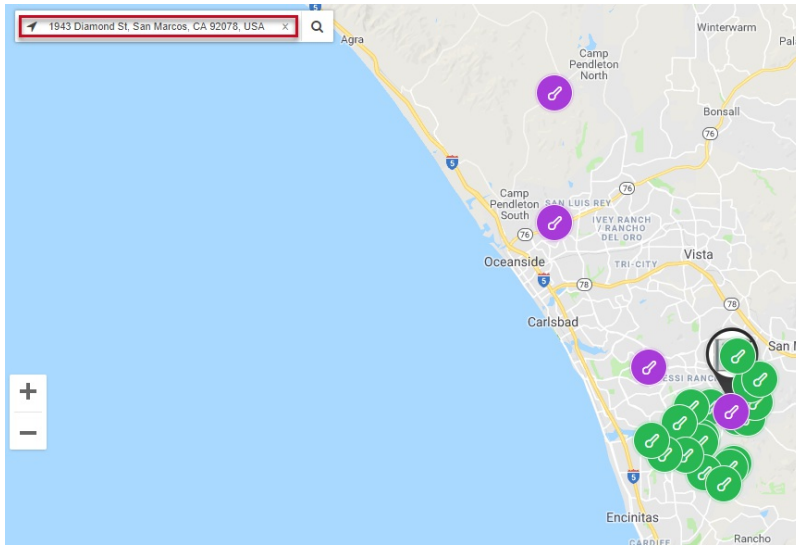

Step 4

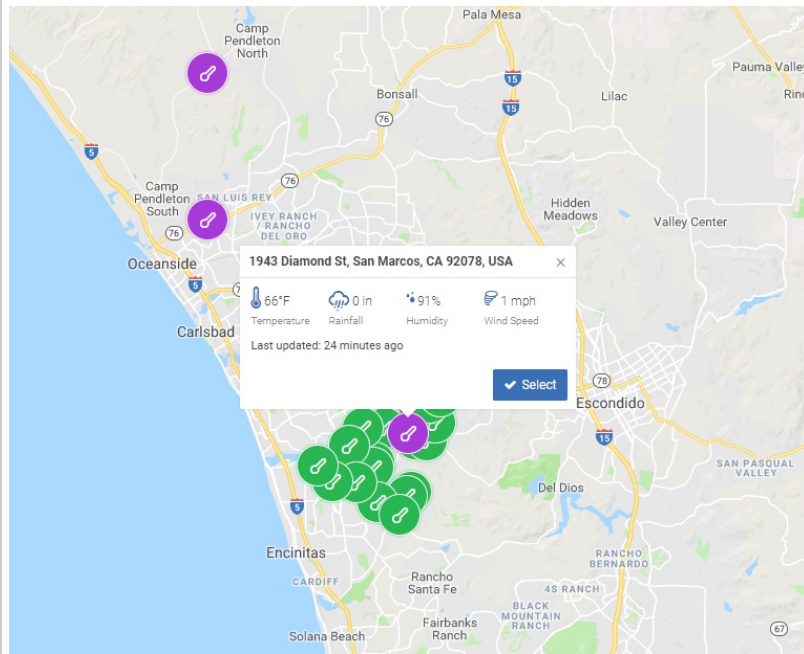

Information from the weather station(s) is used to determine whether to suspend watering (due to high local rainfall for the day or week) or water more (due to high current temperature).

If you have an [Enthusiast Plan or higher](#) [9], we recommend that you select three or more weather stations in your area to average out abnormalities in individual weather stations.

Account - Water Triggers

Hydrawise uses local, real-time weather forecasting and the most accurate weather stations

available to fine-tune your irrigation system to current conditions. Water triggers are the settings in your Hydrawise software that can be adjusted based on your watering requirements.

You can configure watering triggers for either **Time Based watering, Smart (ET) watering or Virtual Solar Sync.**

Time-Based Predictive Watering™

When using the time based watering type, you will have the following options listed below when setting up your zone:

Trigger Options In Station Settings

Predictive Watering™
Adjust watering based on the following triggers

Don't water when:

- Forecast below 60°F
- 80%+ chance of rain
- Wind above 9mph
- 0.5in+ rainfall last day
- 3in+ rainfall last 7 days

Adjust watering:

- Water 30% less when below 73°F
- Water longer when hot
- Water more often when hot

In addition to daily predictive watering adjustments you can specify monthly adjustments using the chart below

Month	Percentage
Jan	40
Feb	50
Mar	60
Apr	70
May	80
Jun	100
Jul	100
Aug	100
Sep	80
Oct	70
Nov	60
Dec	50

Note: Trigger will not be applied if box is unchecked ().

The timed based triggers can be accessed from the Water Trigger section on the dashboard. To configure your **Predictive Watering™** triggers click on Watering Triggers. You will see the options listed below:

Water Triggers

Predictive Watering™ Adjustments

Manage your watering based on weather forecasts. Choose which adjustments to apply when editing a zone.

The interface displays several adjustable settings:

- Temperature Triggers:**
 - Don't water when today's forecast temperature is less than **60 F**.
 - Water **30% less** when today's forecast temperature is less than **73 F**.
 - Water **100% more** when today's forecast temperature is above **90 F** and humidity is below **100%**.
- Rain and Wind Triggers:**
 - Don't water when the chance of rain is higher than **80%**.
 - Don't water when today's forecast wind speed is higher than **9 mph**.
- Smart Watering Options:**
 - Use forecast temperature to predict smart watering (toggle on).
 - Use forecast rainfall to predict smart watering (toggle on).

Weather Station Adjustments

Automatically stop your watering based measurements from your weather stations

The interface displays two rainfall-based triggers:

- Don't water when the last 24hr rainfall is higher than **0.5 in**.
- Don't water when the last 7 days rainfall is higher than **3 in**.

Time Based: Quick Reference Chart

Trigger	Adjustment
Don't water when today's forecast temperature is less than..	(Slider Edit for Temperature)
Water 30% (Edit) less when today's forecast temperature is less than	(Edit) + (Slider Edit for Temperature)
Water 100% (Edit) more when today's forecast temperature is above and humidity is below 100%	(Edit) + (Slider Edit for Temperature)
Don't water when the chance of rain is higher than	(Slider Edit for %)
Don't water when today's forecast wind speed is higher than	(Slider Edit for Wind)
Don't water when the last 24 hr rainfall is higher than	(Slider Edit for Rain)
Don't water when the last 7 days rainfall is higher than	(Slider Edit for Rain)

For more information on the following triggers below for Time Based Watering, click on the links:

[Water more often when hot](#) ^[10]

Smart (ET) Watering

Using forecast evapotranspiration helps to predict the right watering schedule for your zones, giving you a more accurate picture of when the zones will next run.

You can choose whether to use the forecast temperature to predict smart (ET) watering, and whether to use forecast rainfall to delay smart (ET) watering. Watering Schedules will be estimated up to 30 days from today based on forecast and historical temperatures and rainfall. The predicted schedules will be progressively updated each day based on actual weather conditions and new forecasts.

Your watering schedule is updated based on actual weather conditions shortly before your first Program Start Time each day.

You can view the watering adjustments for Smart Watering by clicking [here](#) [12].

For more information on how Time Based Watering works compared to Smart Watering please check out our video guide [here](#) [13].

Trigger Options In Station Settings

Predictive Watering™
Your schedule is adjusted each day using ET from your weather stations. In addition to ET adjustments you can use the following Watering Triggers:

Don't water when:

- Forecast below 60°F

Predict watering using:

- Forecast ET
- Forecast rainfall

In addition to daily ET adjustments you can specify a monthly adjustment using the chart below

Month	Percentage
Jan	100
Feb	100
Mar	100
Apr	100
May	100
Jun	100
Jul	100
Aug	100
Sep	100
Oct	100
Nov	100
Dec	100

Note: Trigger will not be applied if box is unchecked ().

The Smart (ET) Watering triggers can be accessed from the Water Trigger section on the dashboard. To configure your **Predictive Watering™** triggers click on Watering Triggers. You will see the options listed below:

Water Triggers

Predictive Watering™ Adjustments

Manage your watering based on weather forecasts. Choose which adjustments to apply when editing a zone.

The interface displays several adjustable settings for predictive watering:

- Temperature-based adjustments:**
 - Don't water when today's forecast temperature is less than **60 F**.
 - Water 30% less when today's forecast temperature is less than **73 F**.
 - Water 100% more when today's forecast temperature is above **90 F** and humidity is below 100%.
- Rain and Wind-based adjustments:**
 - Don't water when the chance of rain is higher than **90 %**.
 - Don't water when today's forecast wind speed is higher than **62 mph**.
- Smart Watering Predictions:**
 - Use forecast temperature to predict smart watering (On/Off).
 - Use forecast rainfall to predict smart watering (On/Off).

Weather Station Adjustments

Automatically stop your watering based measurements from your weather stations

The interface displays two rainfall-based adjustments:

- Don't water when the last 24hr rainfall is higher than **0.5 in**.
- Don't water when the last 7 days rainfall is higher than **2 in**.

Smart (ET) Watering: Quick Reference Chart

Trigger	Adjustment
Uses forecast temperature to predict smart watering	(On/Off)
Uses forecast rainfall to predict smart watering	(On/Off)

Virtual Solar Sync™

When using the Virtual Solar Sync type, you will have the following options listed below when setting up your zone:

Trigger Options In Station Settings

--

Predictive Watering™

Adjust watering based on the following triggers

Don't water when:

- Forecast below 60°F
- 80%+ chance of rain
- 3in+ rainfall last 7 days
- Wind above 9mph
- 0.1in+ rainfall last day

In addition to daily ET adjustments you can specify a monthly adjustment using the chart below

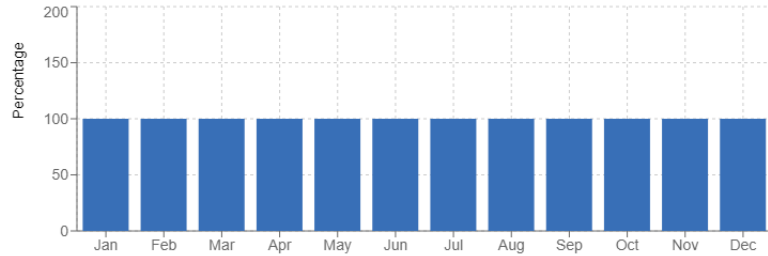

Note: Trigger will not be applied if box is unchecked ().

The VSS triggers can be accessed from the Water Trigger section on the dashboard. To configure your **Predictive Watering™** triggers, click on Watering Triggers. You will see the options listed below:

Water Triggers

Predictive Watering™ Adjustments

Manage your watering based on weather forecasts. Choose which adjustments to apply when editing a zone.

Don't water when today's forecast temperature is less than **60 F**

Water 30% less when today's forecast temperature is less than **73 F**

Water 100% more when today's forecast temperature is above **90 F** and humidity is below **30%**

Don't water when the chance of rain is higher than **80%**

Don't water when today's forecast wind speed is higher than **9 mph**

Use forecast temperature to predict smart watering

Use forecast rainfall to predict smart watering

Weather Station Adjustments

Automatically stop your watering based measurements from your weather stations

Don't water when the last 24hr rainfall is higher than **0.1 in**

Don't water when the last 7 days rainfall is higher than **3 in**

Virtual Solar Sync: Quick Reference Chart

(Slider Edit for

Don't water when today's forecast temperature is less than	Temperature)
Don't water when the chance of rain is higher than	(Slider Edit for %)
Don't water when today's forecast wind speed is higher than	(Slider Edit for Wind)
Don't water when the last 24 hr rainfall is higher than	(Slider Edit for Rain)
Don't water when the last 7 days rainfall is higher than	(Slider Edit for Rain)

Account - Running Zone(s) Manually

You can run an irrigation zone on demand from from your web browser or from your iPhone/Android app. For running manual from the controller, see article [here](#) ^[14].

Manual Single Station

Please view the steps and screenshots to access this feature:

1. From the home dashboard, click on the **"zone icon."**
2. Select the **"play button."**
3. Select a **"customer length or normal run length."**
4. Click **"run now."**

STEPS 1-2

The screenshot shows the 'Watering Schedule for Diamond Street Controller' interface. At the top, there is a blue header with a gear icon and a dropdown arrow. Below the header is a light blue information box that says 'Click on any of your zones below to manually change their watering schedules'. The main area features three green circular icons representing different zones: 'Front Grass', 'Lowes', and 'Back Drip'. A tooltip is visible over the 'Front Grass' icon, displaying 'Next Run' (Wed, 26th Sep 5:00am), 'Length' (5 minutes), and 'Last Water' (4 hours 50 minutes ago). Below the zones, there are weather forecasts for Tuesday (73°F, Partly Cloudy), Wednesday (77°F, Sunny), and Thursday (81°F, Partly Cloudy). A red box highlights a play button icon in the bottom left corner of the interface.

STEPS 3-4

The screenshot shows a dialog box titled 'Manually Start a Zone'. The question asks 'How long would you like to run Front Grass for?'. There are two options: 'Normal length' (selected) and 'Custom length'. Below the options, it says 'Run Front Grass for its normal watering length'. A green 'Run Now' button is prominently displayed, and a 'Cancel' button is located at the bottom right.

Manual All Stations

1. From the home dashboard, click on the "gear with drop down arrow."
2. Select the "run all zones."
3. Select a "customer length or normal run length."
4. Click "run now."

STEPS 1-2

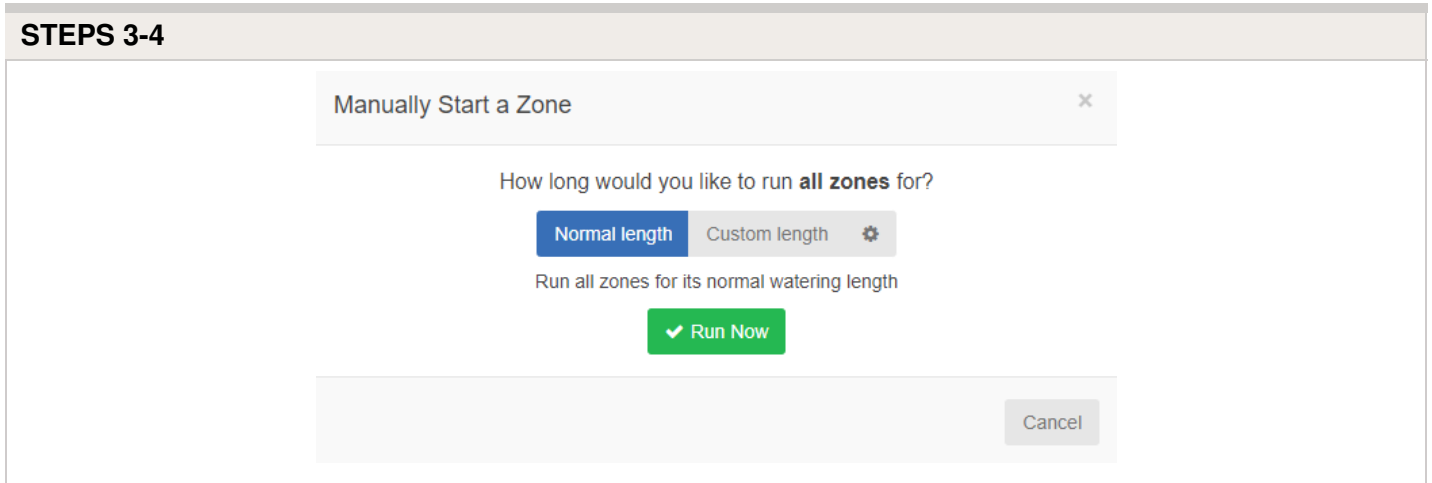
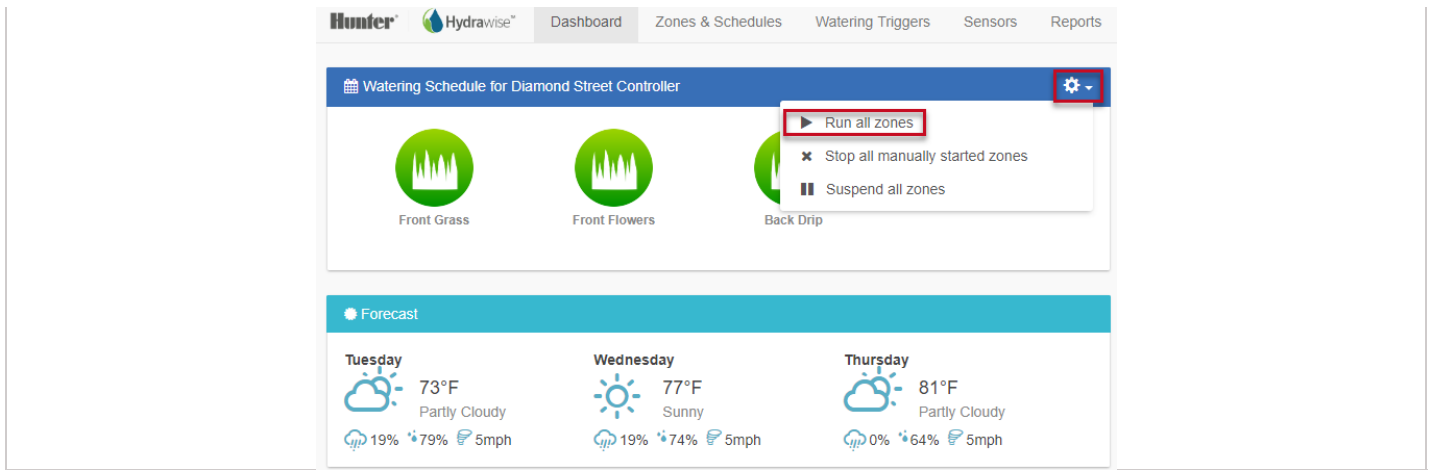

TIP: To stop a zone that is currently running, click the **Stop**  button on your Dashboard.

Accounts - Reports

You can access reports for your controllers by selecting Reports from the main menu and selecting the three lines at the bottom for the mobile version. Use the settings on the report tab to the right of the screen to change the following:

- Change the date range for the report
- Clear all report data
- Download a report to Excel
- Refresh a report

- View all report data

1. Select the **"Reports"** tab on the left hand side on the dashboard.
2. Select one of the four report options to view the data.

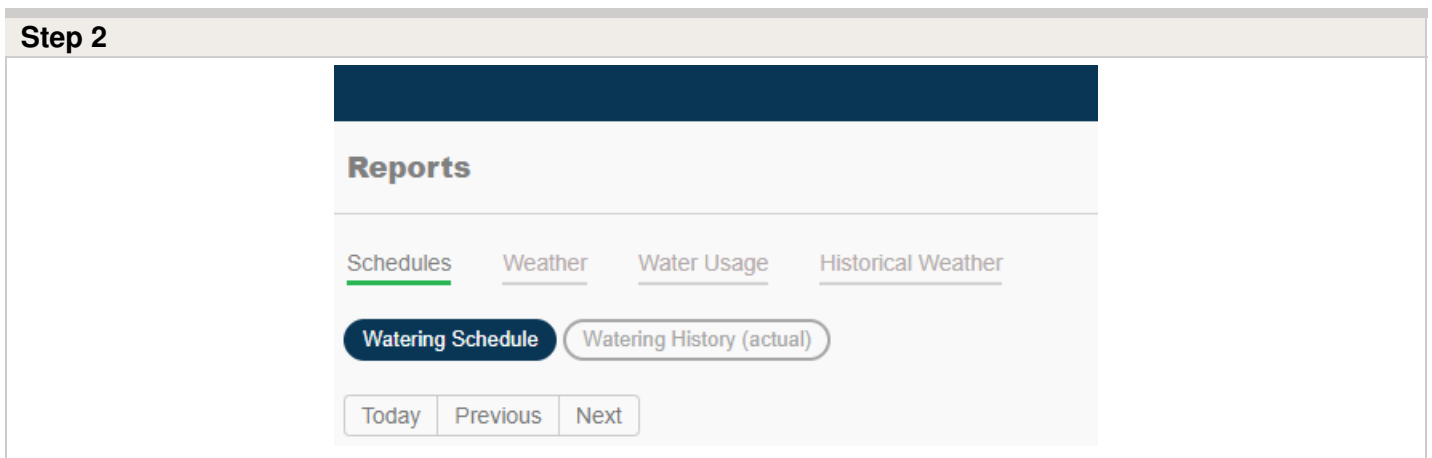
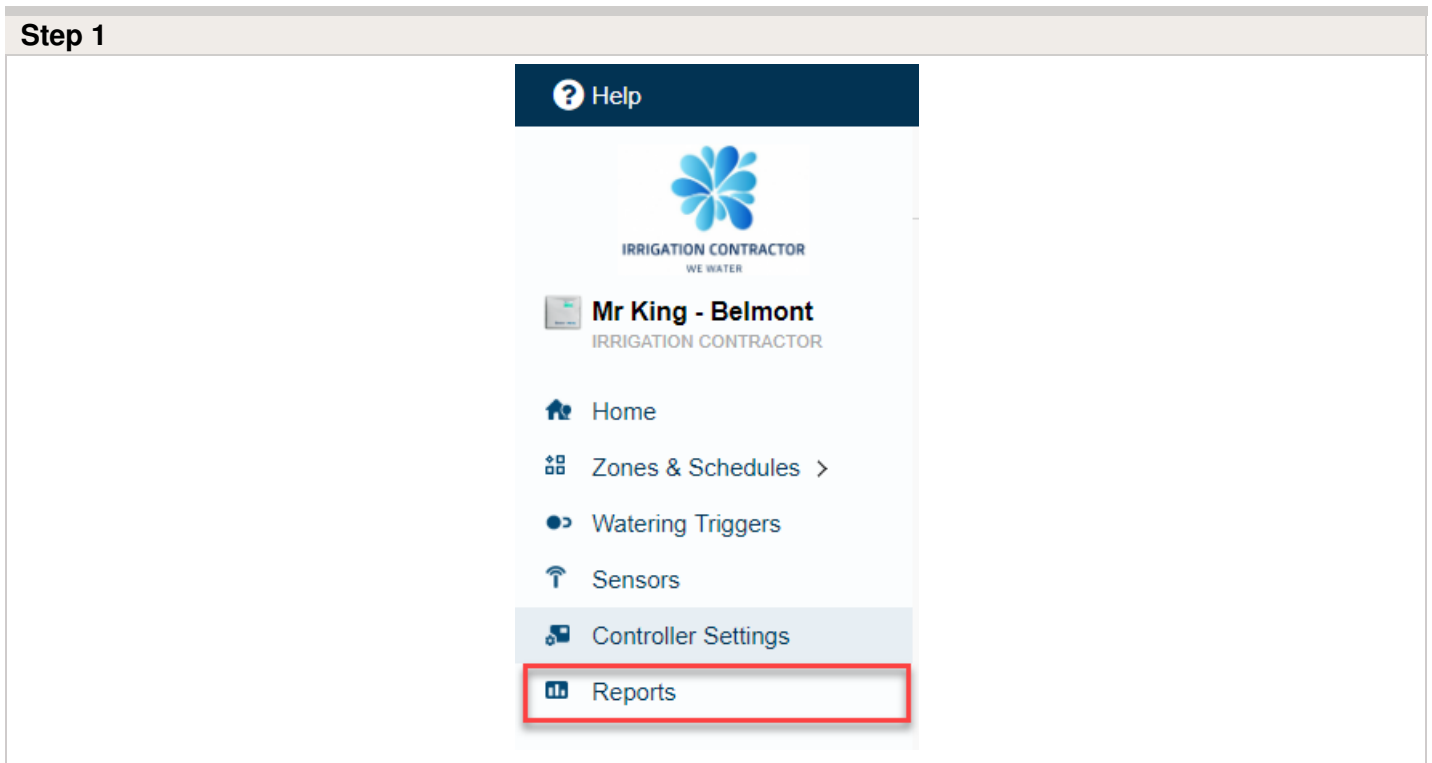

Below you will find all the different report names and description of each.

Schedule	
Report Name	Description
Watering Schedule	Shows the scheduled watering time for each zone. You can hover over each schedule to

	see more details about the planned watering.
Watering History (Actual)	Shows actual completed watering time for each zone. You can hover over each watering time to see more details about the watering.

Weather	
Report Name	Description
Weather Forecast	Show the historical weather forecast plus the next 3 days, forecast. Your controller will use this forecast to adjust your watering schedule.
Weather Station Temperatures	Shows daily maximum temperatures for each weather station to which the controller is subscribed. You can click on the weather station names at the bottom of the report to show their information in the report or exclude it.
Weather Station Rainfall	Shows daily rainfall for each weather station to which the controller is subscribed. You can click on the weather station names at the bottom of the report to show their information in the report or exclude it.
Weather Station Wind Gust	Shows wind gusts for each weather station to which the controller is subscribed. You can click on the weather station names at the bottom of the report to show their information in the report or exclude it. Hover over any wind gust bar to see further information.

Evapotranspiration (ET)	Shows daily evapotranspiration for each weather station to which the controller is subscribed. You can click on the weather station names at the bottom of the report to show their information in the report or exclude it.
-------------------------	--

Water Usage	
Report Name	Description
Water Saving	Shows the estimated water saving for your controller over the last 7 days. During cold weather you would expect to see this percentage increase due to reduced watering. During hot weather you would expect to see this percentage decrease (and go negative) as the controller increases watering.
Flow Meter Measurements	If you have a flow meter installed, this report shows reported flow for each of your controller's zones.
Total Water Usage	Shows daily water usage as recorded by each flow meter. Also shows minimum and maximum water usage for any flow meter across the period as well as the average and total water usage. You can click on the flow meter names at the bottom of the report to show their information in the report or exclude it. Hover over any flow meter bar to see how many zones were active at the time.
Flow Rates (per minute)	If you have a flow meter installed, this report shows instantaneous flow rates each time the controller records flow. Hover over any dot to see the flow rate and number of zones active at the time.

Sensor Levels	If you have a rain sensor, moisture sensor or any other 'level' based sensor configured this report will show the historical status of your sensor (open or closed).
Smart Water Balance	Shows the irrigation balance for each zone on a given day. Also shows the minimum and maximum irrigation balance over the report period. You can click on the zone names at the bottom of the report to show their information in the report or exclude it. Hover over the graph to see information on evapotranspiration, rainfall and irrigation amounts.
Virtual Solar Sync	Shows the Solar Sync adjustment by a date and percentage.

Diagnostics	
Report Name	Description
Solenoid Load	<p>150 – 449mA = 1 solenoids</p> <p>450 – 749mA = 2 Solenoids</p> <p>750 + = 3 solenoids</p> <p>Greater than 880 mA and the controllers will trip out on the overload.</p>

Historical Weather	
Report Name	Description
Monthly Evapotranspiration and Rainfall	Shows the historical ET and rainfall in your area. This data is based on a 12 year average
Monthly Temperature and Rainfall	Shows the historical temperature and rainfall in your area. This data is based on a 12 year average.

Account - Controller Configuration

To change the configuration of your controller, select **Controller Settings** from the menu on the left hand side.

Please view the screenshot below to access this feature:

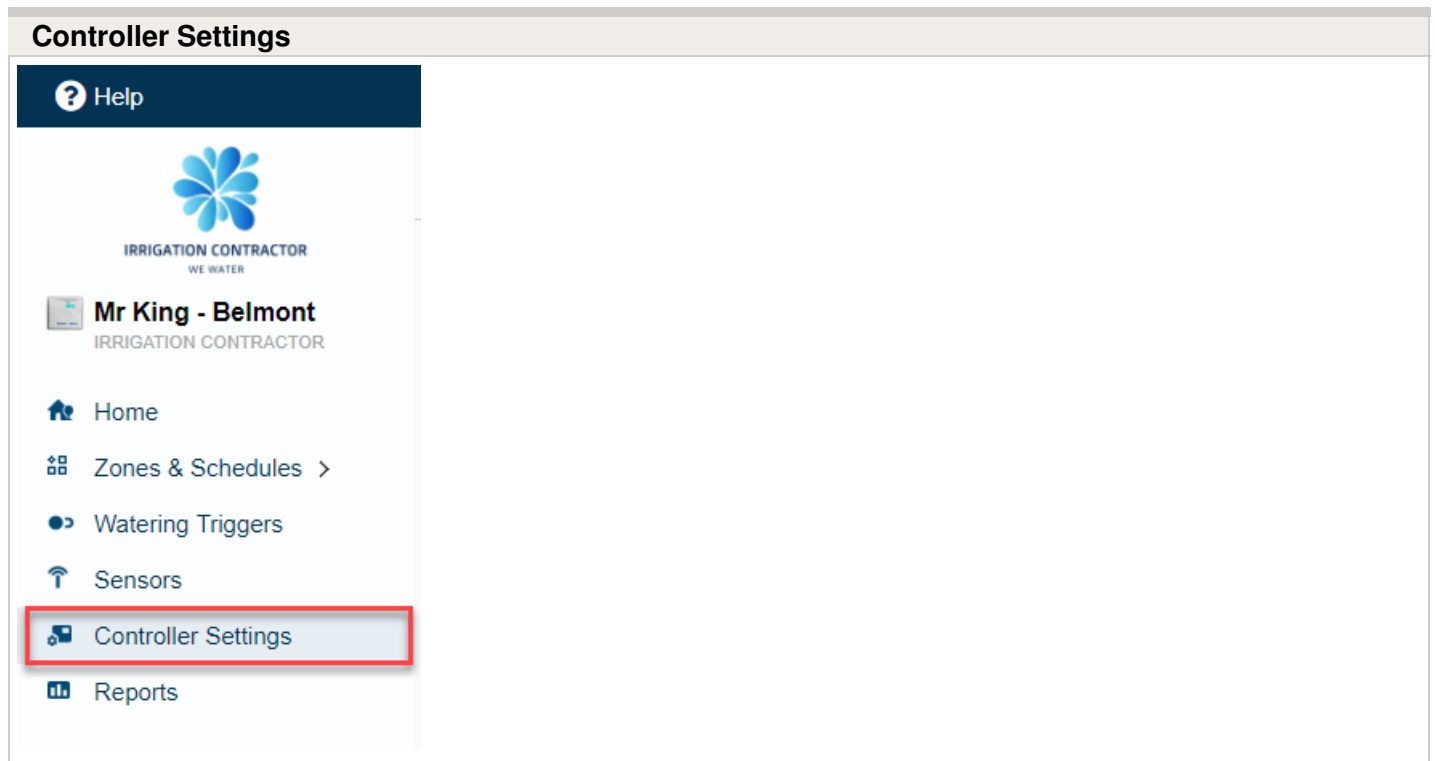

Controller Settings

Configuration Options	
Controller Name	The name of your controller
Serial Number	The controller's serial number. Click 'Remove Serial' to remove the serial number and replace it with another physical controller
Notification Email	The email address notifications are sent to when the controller is offline, or Hydrowise needs to contact you (for example when your subscription plan is about to end)
Notify	The amount of time that your controller is offline for before we notify you
Units	The units used for reports, alerts and elsewhere in the app
Inter Zone Delay	The number of seconds to insert between each zone watering when calculating scheduled
Master Valve Delay	The minimum number of seconds that the master valve should be active before any zone starts
Hide password	If set to yes, this will hide your wireless password on the controller. If your controller is in a publicly accessible area we recommend you hide your password.

Controller Settings Page

Controller Settings for My Controller

CONTROLLER

- NAME: Hunter Industries
- SERIAL NUMBER: V14563 [Remove Serial](#)
- STATUS: Linked
- MODEL: HC 6 Zone Controller
- INSTALL DATE: Mon, 19 Sep 16 02:07:37 +0000
- SOFTWARE

OFFLINE NOTIFICATIONS

- NOTIFICATION EMAIL: anthony+4@hydrowise.com
- NOTIFY: After no contact for 1 day

REGIONAL SETTINGS

- TIMEZONE: America/Los_Angeles

INTERNET SETTINGS

- OFFLINE MODE
- HIDE WIFI PASSWORD: No
- DISABLE LOCAL ACCESS: No

VALVE DELAYS

- INTER ZONE DELAY: 0 seconds
- MASTER VALVE DELAY: 3 seconds

Expansion Modules

This section you can see your expansion modules and when they last made contact. You can also add or remove expansion modules. Up to 2 expansion modules can be added to a single Hunter HC controller.

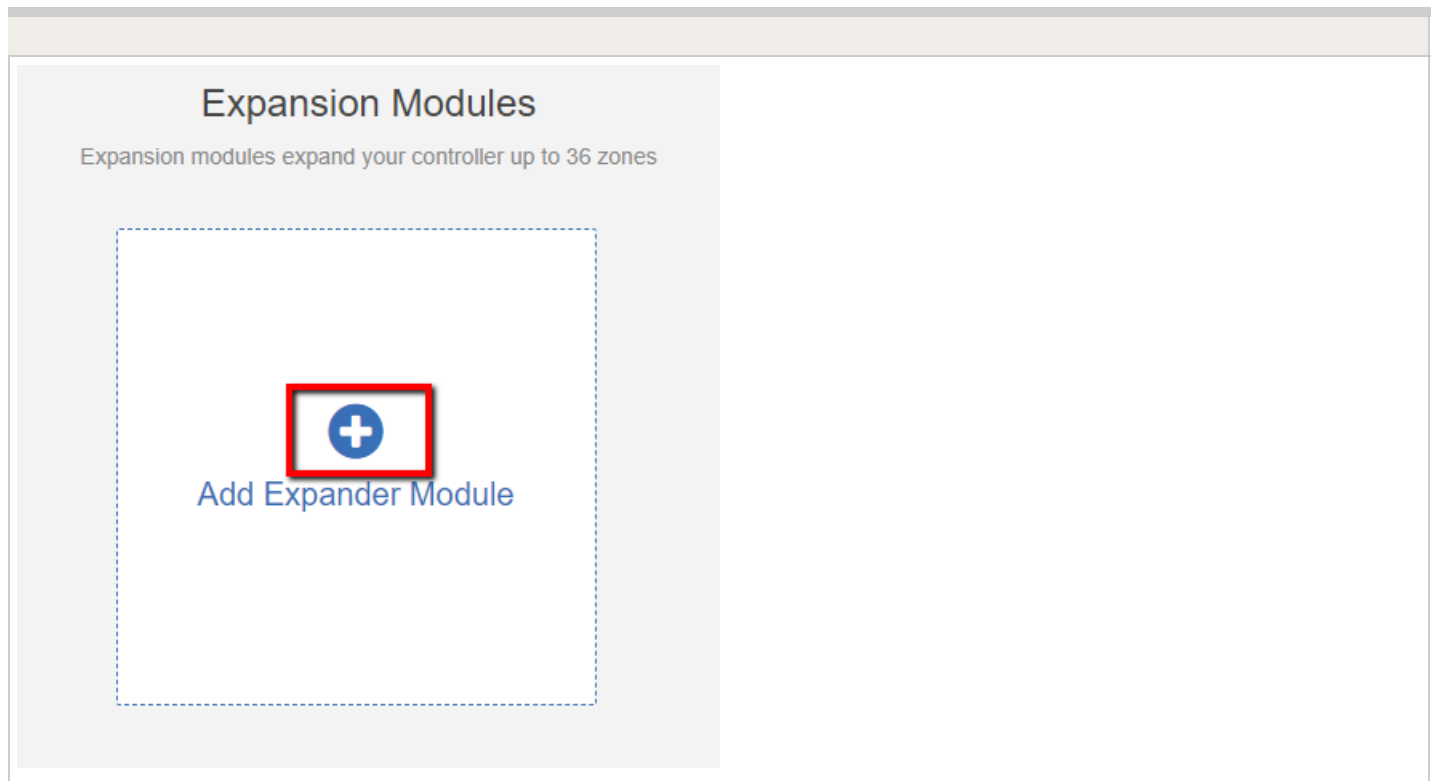

When you add an expansion module, you will need to give it a name and specify the ID number that you selected when setting up the module. This number needs to match the number at the physical expansion module as well.

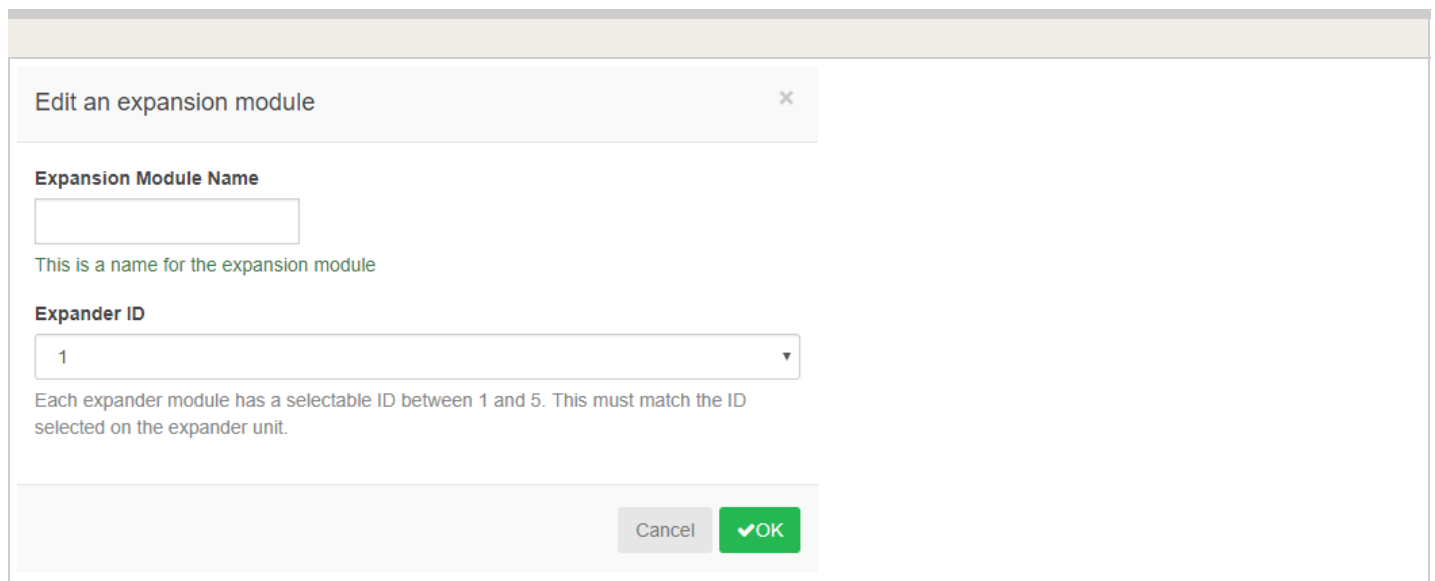
A screenshot of a dialog box titled "Edit an expansion module" with a close button (x) in the top right corner. The dialog contains two input fields. The first is labeled "Expansion Module Name" and is an empty text box. Below it is a note: "This is a name for the expansion module". The second is labeled "Expander ID" and is a dropdown menu currently showing "1". Below it is a note: "Each expander module has a selectable ID between 1 and 5. This must match the ID selected on the expander unit." At the bottom right of the dialog are two buttons: "Cancel" and "OK" (with a green checkmark).

Offline Water Adjustments

Offline water adjustments allow the controller to automatically adjust the amount of watering on a month- by-month basis if the controller is in an Offline mode (ie. if is not connected to the internet).

<input type="checkbox"/>

Account - Account Details

Account Details

Here you can change your password, change your plan and change your account visibility settings. By default, nobody else can see your account. However, if you want help from a Hydrowise contractor then you can choose to make your account visible to the contractor so that they can help you with configuration or troubleshooting.

1. Click the "**My Account Settings**" tab in the top right hand corner to view "**Account Details**".

My Account

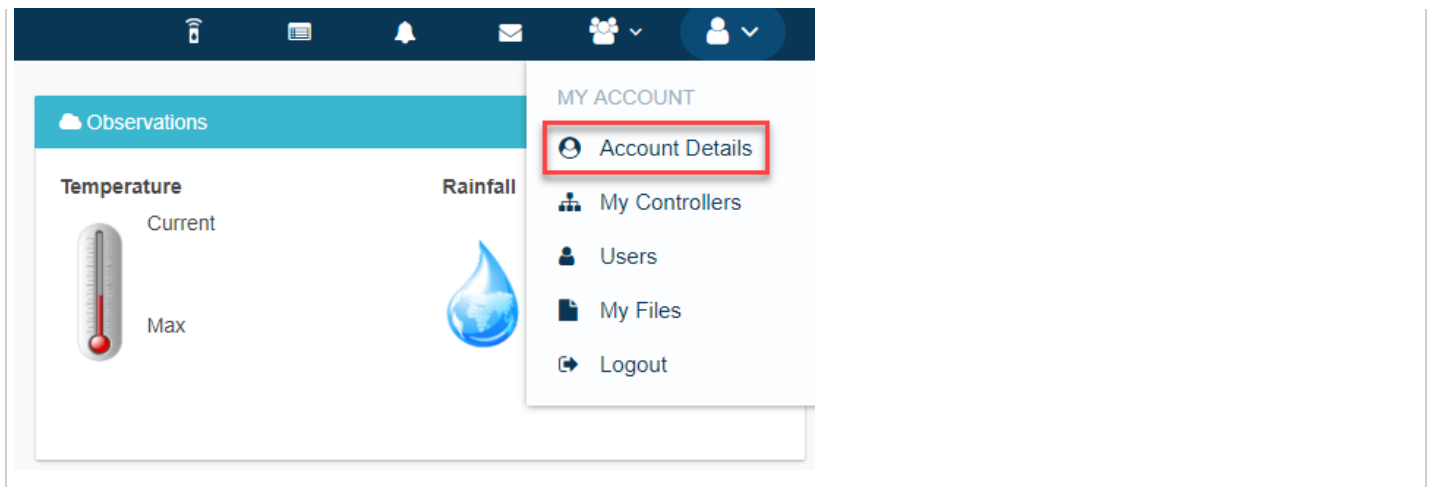

You can view/edit the following in the account details section:

1. **User Settings**
2. **Account Settings**
3. **Plan Details**
4. **Privacy settings**

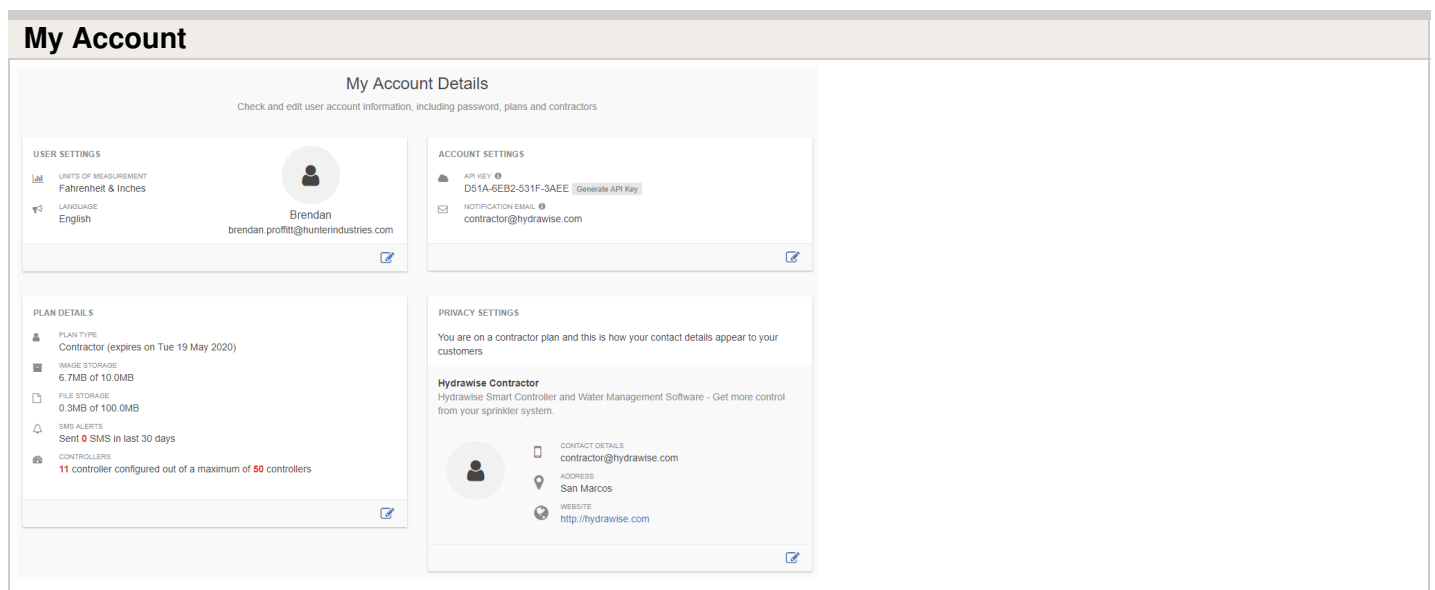

User Settings

From this screen, you can change the following:

1. Name of user
2. Email address
3. Picture of user

- 4. Change the units of measurement
- 5. Edit password.

Edit User

Edit User ✕



[Change picture](#)

Name

Email Address

Units of Measurement

Account Settings

From this screen, you can change the following:

- 1. Choose the user that notifications for account issues should be sent out.

Edit Notification Email

Edit Notification Email ✕

Accounts

Choose the user that notifications for account issues should be sent to

Plan Details

From this screen, you can view the plan type, image storage, file storage, SMS alerts, and controller amount. You can **edit** the following: change or upgrade plan.

Choose Plan

Choose Your Subscription Plan

Home Owner Plans Contractor Professional Plans

The Hydrowise system is free for most users worldwide. For those interested in even more w the Enthusiast Plan provides access to more than 100,000 personal, airport and official weatl

Home

Free

- ✓ Select from over 10,000 Airport Weather Stations
- ✓ Monitor 1 Weather Station Simultaneously
- ✓ Daily Schedule Updates

Enthusiast

- ✓ Select from c and Personal
- ✓ Monitor up to Simultaneous
- ✓ Hourly Schec

Privacy settings

From this screen, you can view the contact details, address, and website. You can **edit** the following:

1. Search and select a contractor you want to manage your controller.
2. Make your account private if previously managed by a contractor.

Contractor Selection

Contractor Selection

Filter by radius 30kms 80kms 160kms

Making Account Private

Contractor Selection

Filter by radius 30kms 80kms 160kms

Here are the closest 6 Hydrawise contractors to you based on your a

Proffitt Construction (Your Contractor) CONTRACTOR STARTER

CONTACT
760-304-7218

LOCATION
1943 Diamond Street, San Marcos, CA, United States

[MAKE ACCOUNT PRIVATE](#)

Contractor Selection

Filter by radius 30kms 80kms 160kms

Account - Viewing Controllers

From the menu, choose the **Controller Name** on the left hand side of the home screen.



Help



IRRIGATION CONTRACTOR
WE WATER





Mr King - Belmont
IRRIGATION CONTRACTOR

- Home
- Zones & Schedules >
- Watering Triggers
- Sensors
- Controller Settings**
- Reports

This will give you a list of all the controllers in your account. Click on the controller name to change to configuring that controller.

Choose the **controller** you want to view.

Choose your controller

Golf Room  PI  1943 Diamond st  1943 Engineering 

Account - Assigning Images on Mobile

Before assigning the image to an individual zone with your mobile device, please make sure it is captured in the correct orientation (landscape) mode as seen in the illustration below:



From the "**Zones Section**", you can assign an image to each zone. Click on the Image Add button  next to the Zone Edit button at the bottom right.

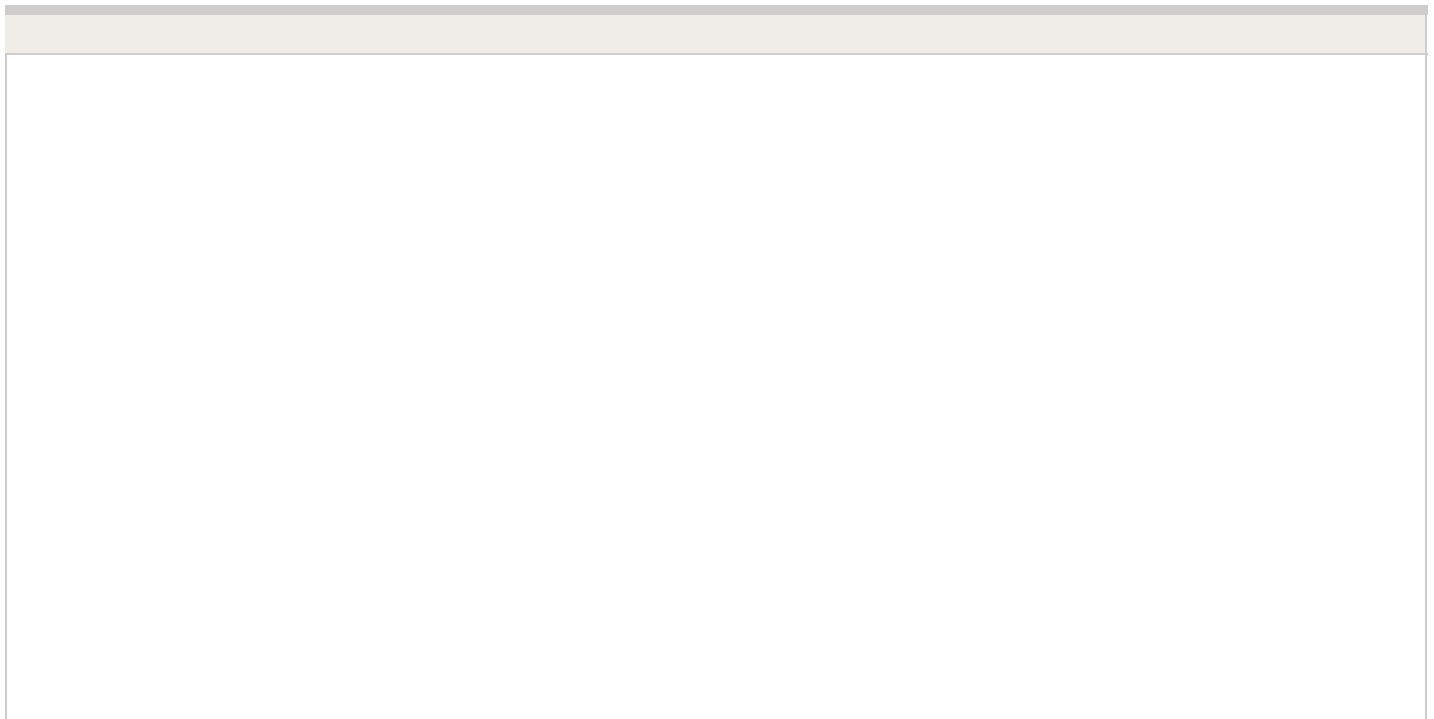

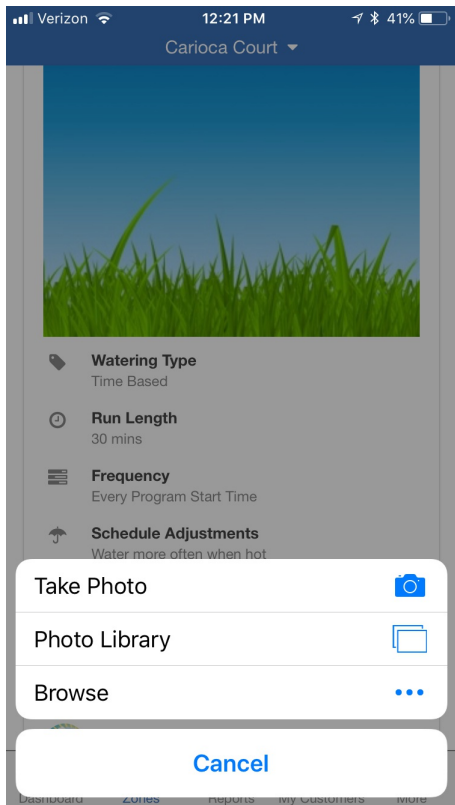
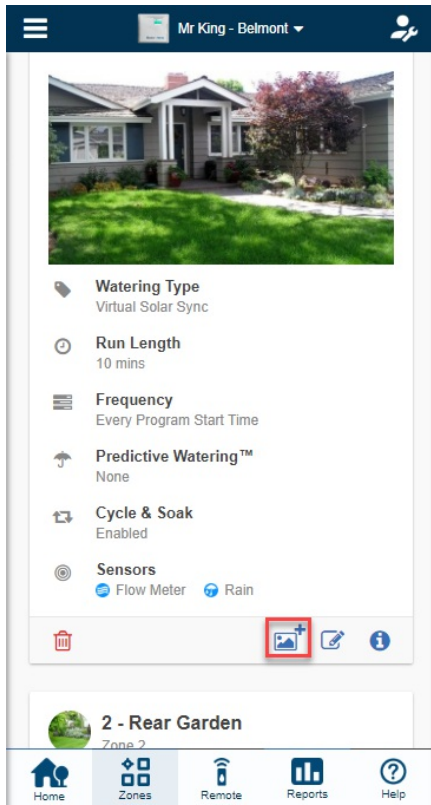

You can **upload** multiple images per zone or take a photo using phone camera. The total number of images that can be uploaded is based on the images size and is different for each account's plan subscription.

After an image is uploaded you can select an image to be displayed on the Dashboard by editing the zone  and selecting the image in the Zone Icon list.

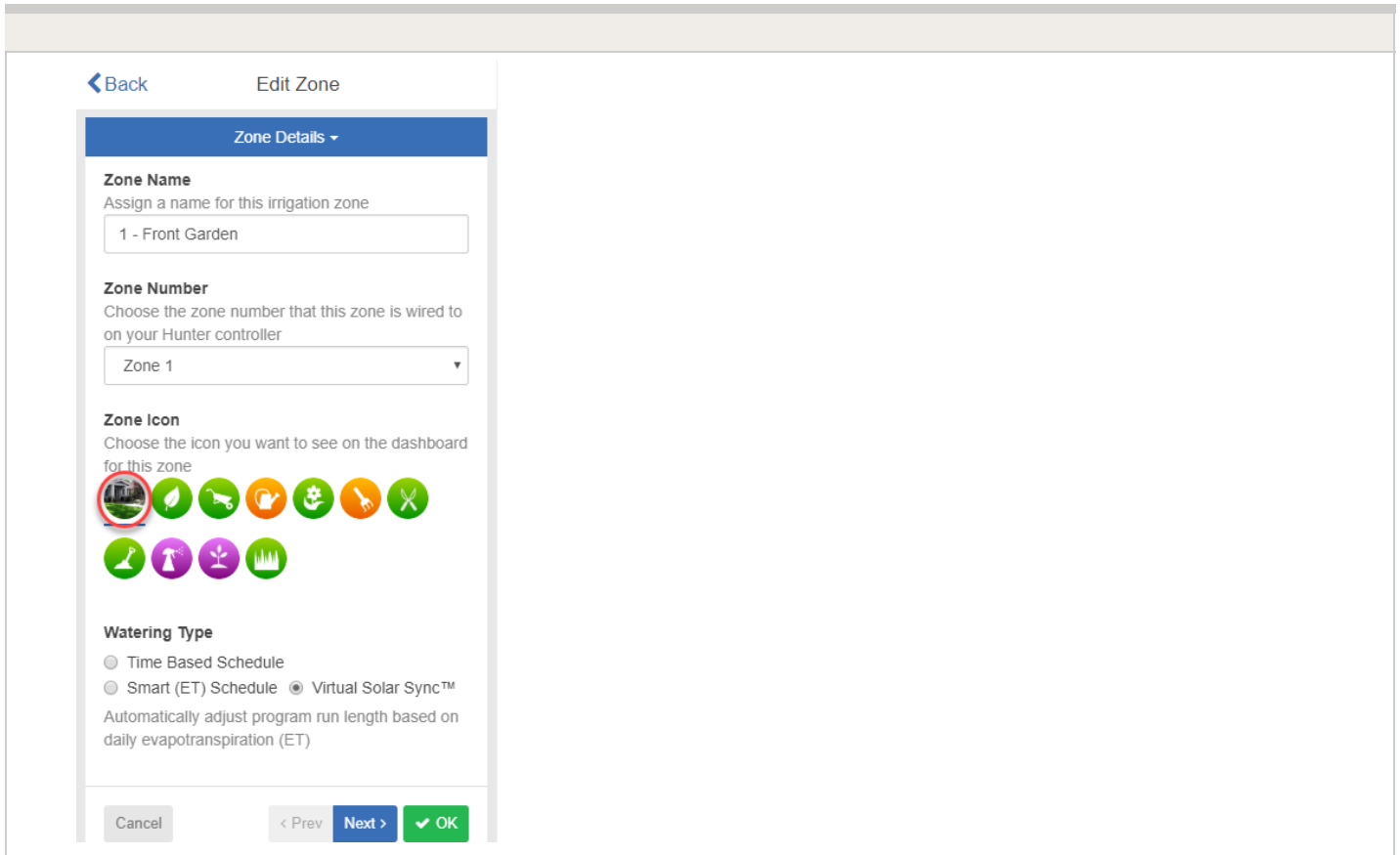

The screenshot shows the 'Edit Zone' interface. At the top left is a blue back arrow and the text 'Edit Zone'. Below this is a blue header bar with 'Zone Details' and a dropdown arrow. The form contains the following sections:

- Zone Name:** 'Assign a name for this irrigation zone' with a text input field containing '1 - Front Garden'.
- Zone Number:** 'Choose the zone number that this zone is wired to on your Hunter controller' with a dropdown menu showing 'Zone 1'.
- Zone Icon:** 'Choose the icon you want to see on the dashboard for this zone' with a grid of 11 circular icons. The first icon, which shows a house with a lawn, is circled in red.
- Watering Type:** Three radio button options: 'Time Based Schedule', 'Smart (ET) Schedule', and 'Virtual Solar Sync™'. The 'Virtual Solar Sync™' option is selected. Below the options is the text: 'Automatically adjust program run length based on daily evapotranspiration (ET)'.

At the bottom of the form are four buttons: 'Cancel', '< Prev', 'Next >', and 'OK'.

To **"Remove"** the image, you can click on the image in the "zones" settings and the following screen will appear. The existing image can be deleted and new one added on the upper right-hand side.

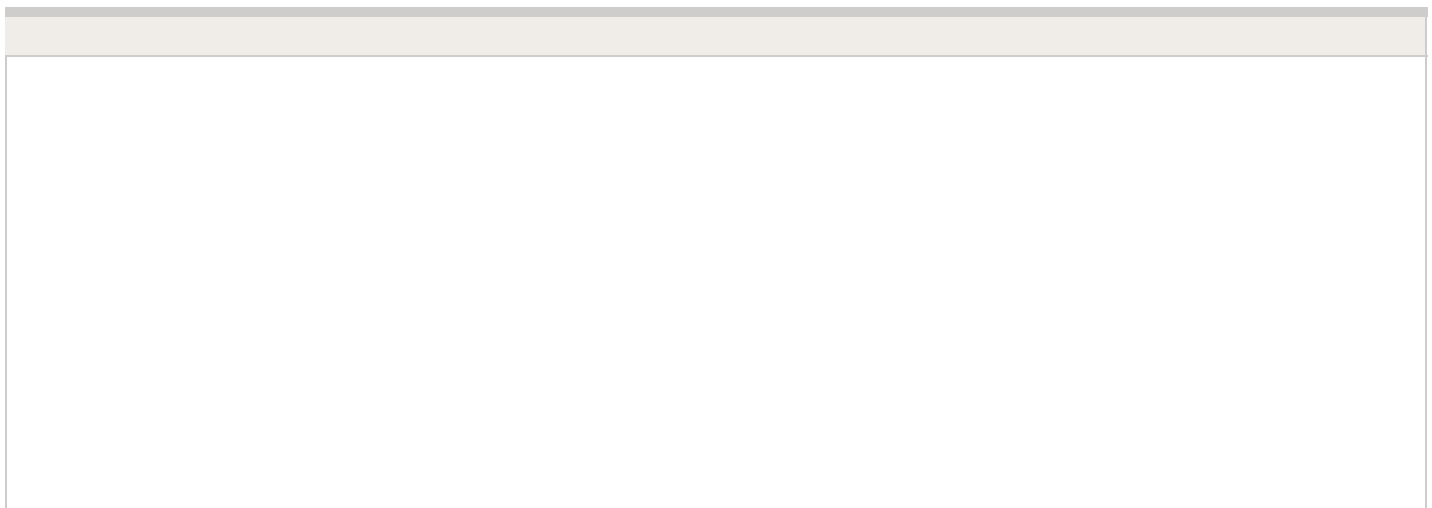

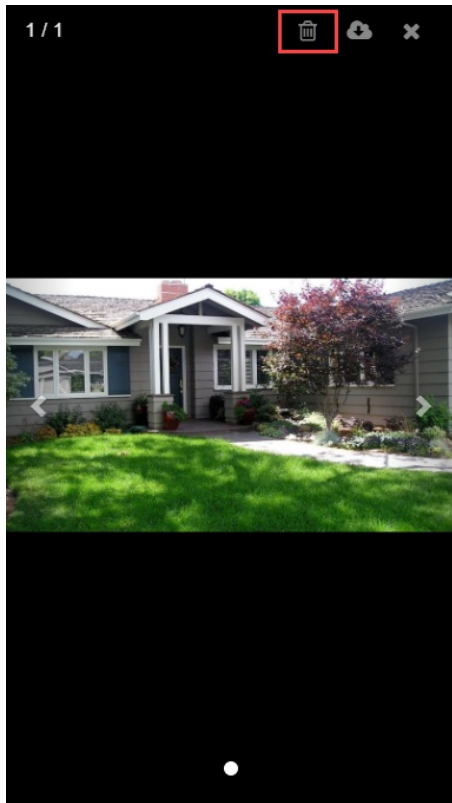

Account - System Shut Off (Winterization)

In the application (Smart Device or PC), you can suspend your system for any period of time for winterization purposes or basic system shut down.

- For information on winterizing using the HC flow meter, [CLICK HERE](#) ^[15].
- For more information on the winterization procedure, [CLICK HERE](#) ^[16].

1. Click on the **gear** above the zones.
2. Next, click "**Suspend all zones.**"

3. Select the date range for which you would like the controller to be suspended. Use the arrow in the gray drop-down box to select a day and month. Once the date is selected, click **suspend**.
4. Your zones should all appear faded and you will get the following message: **“All zones suspended for XX months.”** This message will disappear after a few minutes.
5. If you wish to restart your system before the due date, click the single gear above your zones, and click **“Suspend all zones.”** Then, click **“Remove suspension”** in RED. The suspension will be removed and the system will be ready for watering.

STEP 1

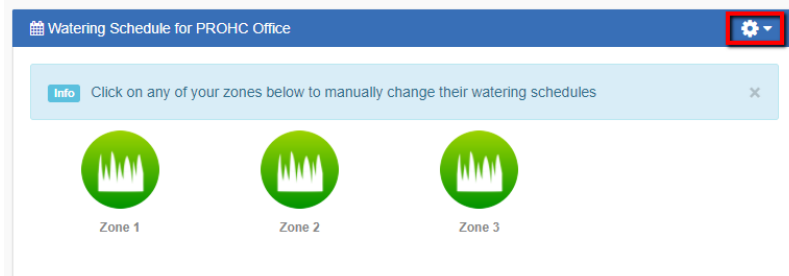

STEP 2

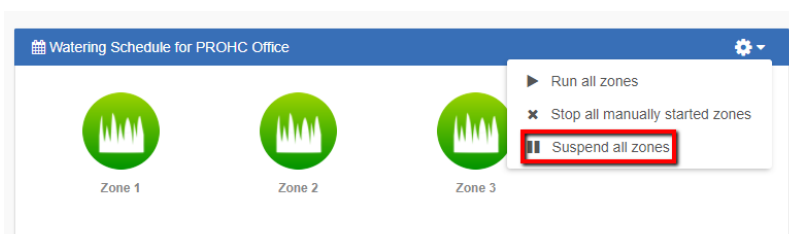

STEP 3

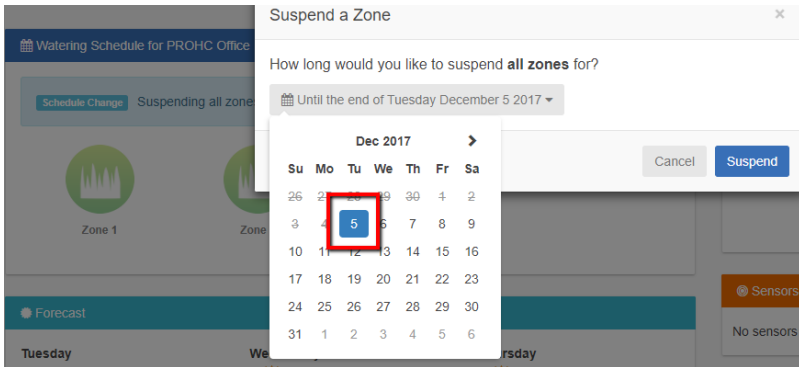

STEP 4

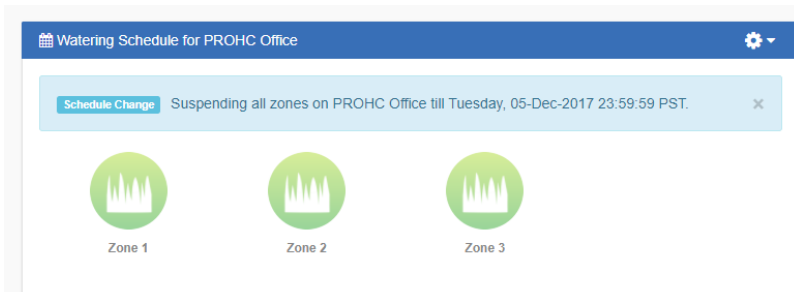

STEP 5

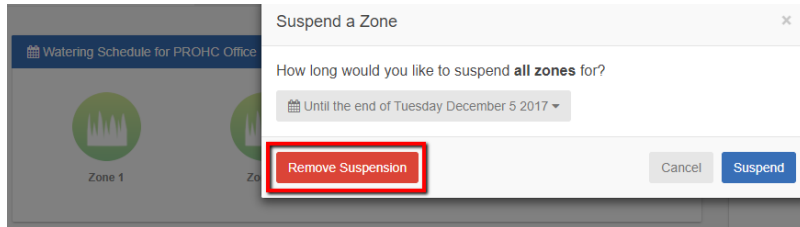

Account - Delete Controller

If you have the need to delete a controller from your account, please use the steps and screenshots listed below:

1. Make sure you are **NOT** currently configuring the controller you would like to delete. Click on the "**current controller name.**"
2. Change controller by selecting another one from the "**Choose your controller**" category.
3. Click on the top right tab to access the "**My Account**" settings.

4. Scroll down to the bottom controller section. Click on the **"three selection dots"** to the right of the controller name you would like to edit.
5. Choose **"Remove Serial Number"** to remove controller from the account.
6. Next, choose **"Delete"** to remove controller from the account.

The controller will now be removed from you account.

STEP 1

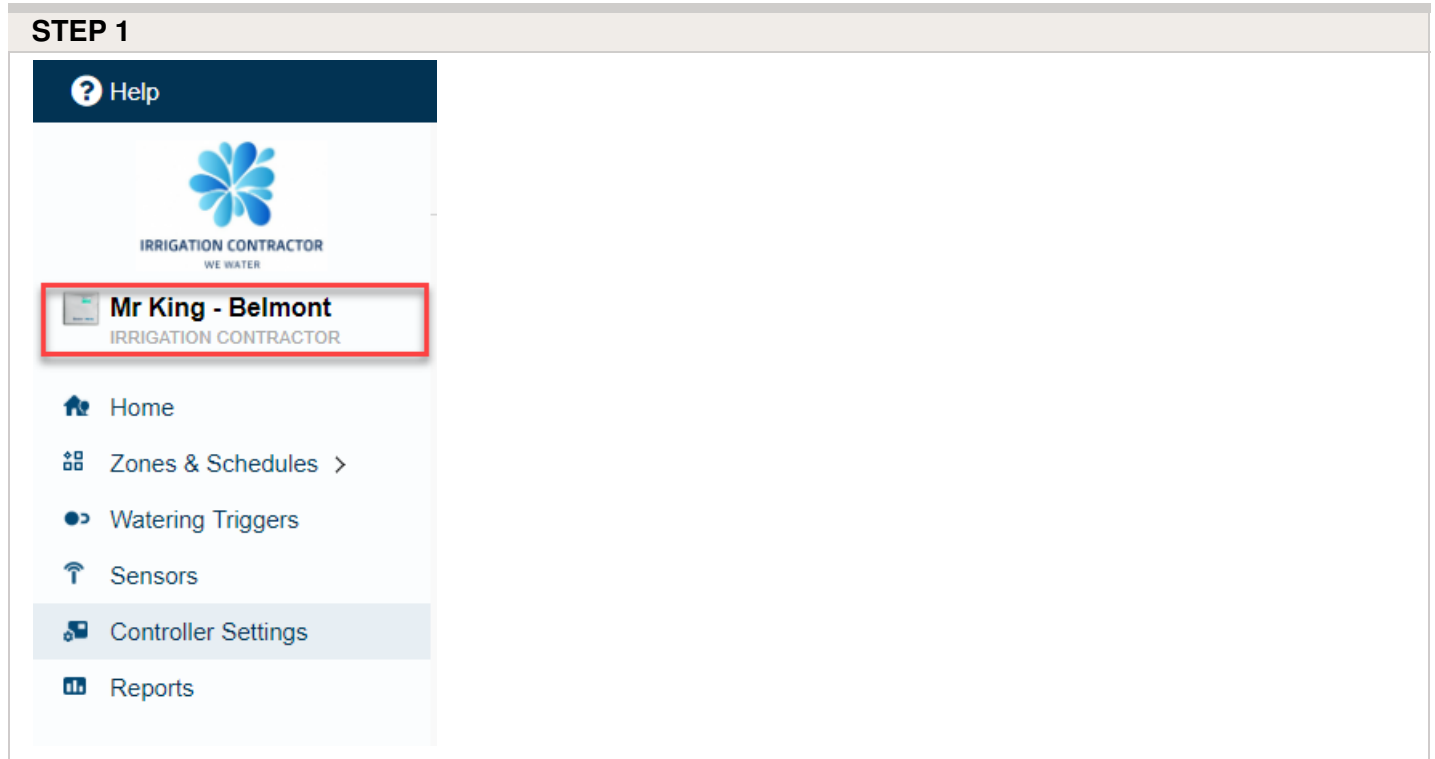

Help

IRRIGATION CONTRACTOR
WE WATER



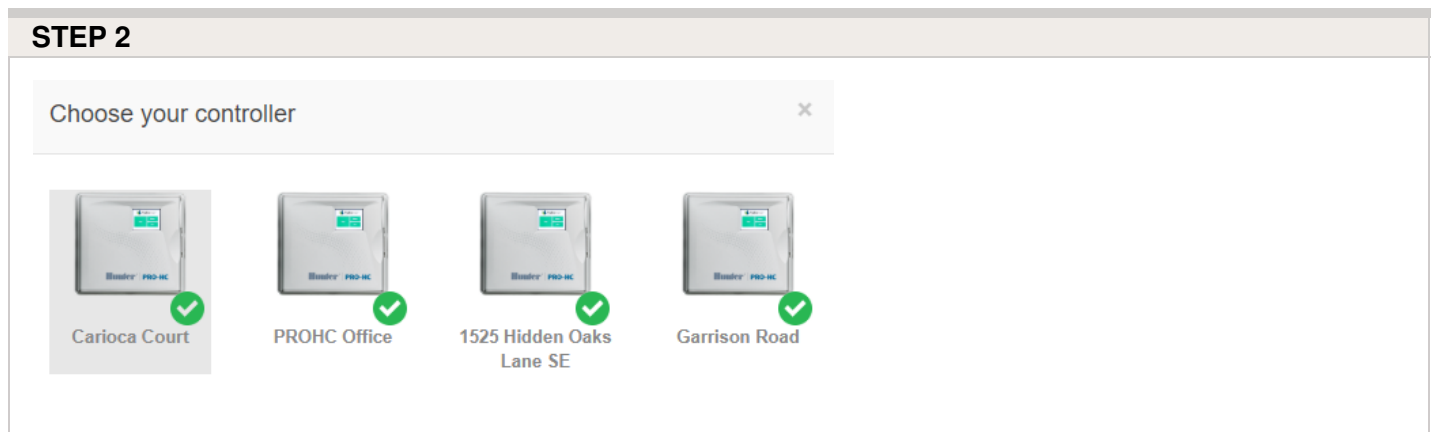

Mr King - Belmont
IRRIGATION CONTRACTOR

- Home
- Zones & Schedules >
- Watering Triggers
- Sensors
- Controller Settings**
- Reports

STEP 2



Choose your controller

- 
Carioca Court ✓
- 
PROHC Office ✓
- 
1525 Hidden Oaks Lane SE ✓
- 
Garrison Road ✓

STEP 3

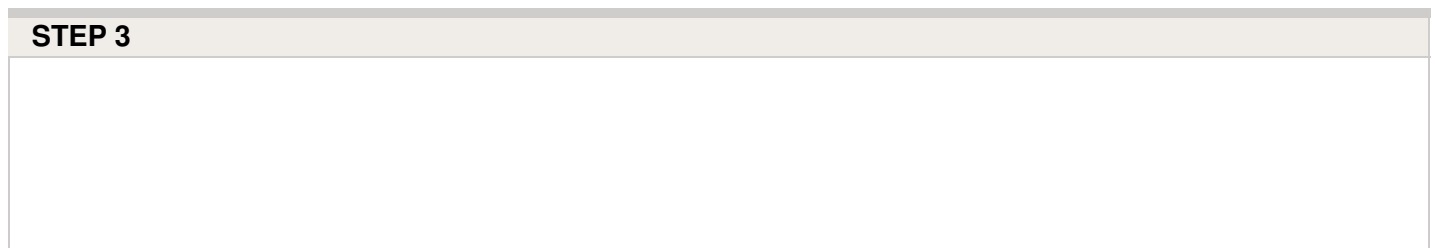

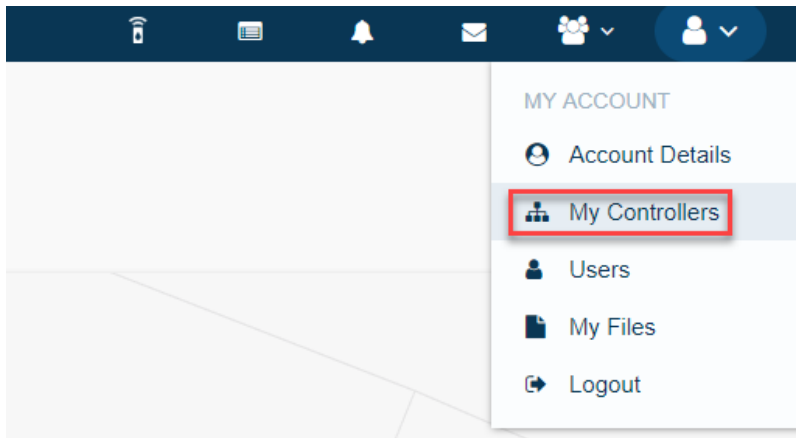

STEP 4

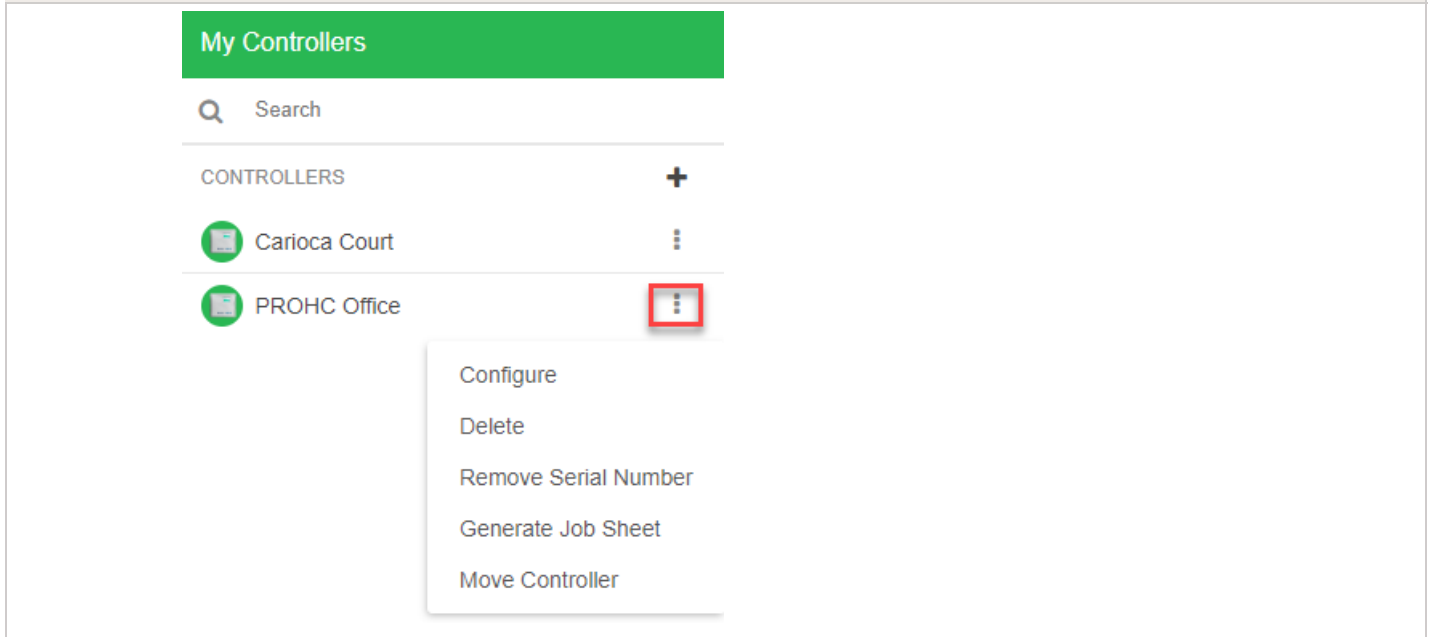

STEP 5

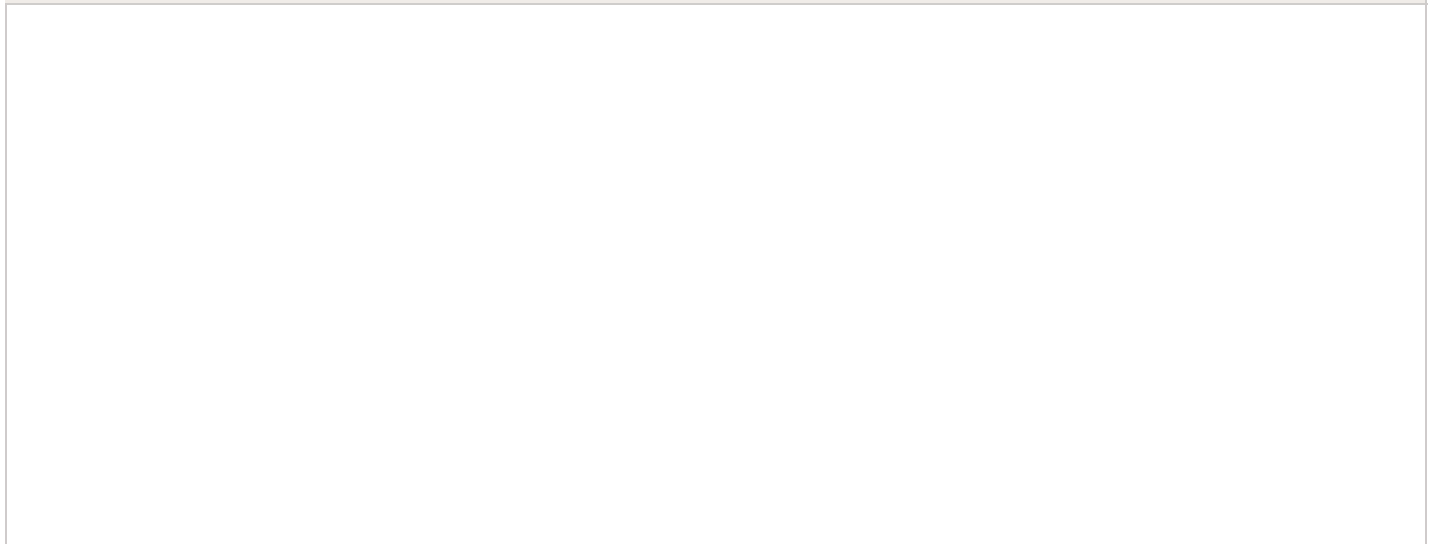

My Controllers

Search

CONTROLLERS +

- Carioca Court
- PROHC Office

Configure
Delete
Remove Serial Number
Generate Job Sheet
Move Controller

STEP 6

My Controllers

Search

CONTROLLERS +

- Carioca Court
- PROHC Office

Configure
Delete
Remove Serial Number
Generate Job Sheet
Move Controller

NOTE: If you attempt to delete a controller that you are currently configuring, the message will appear below.



Information



You cannot delete a controller you are currently configuring

OK

Account - Virtual Weather Station

The Virtual Weather Station is a weather station that is created based on the geographic location of the controller. The station is not real, but uses complex algorithms, satellite data, real weather stations, atmospheric data from airplanes, and pressure readings from mobile phones to calculate a comprehensive, highly accurate history for the selected location. The Virtual Weather Station can now be selected as a weather station and is free to use.

Please view the steps and screenshots to access this feature:

1. Click on **"Controller Settings"** from the home dashboard, then select **"Weather Stations."**
2. Your free **"Virtual Weather Station"** should already be shown at your address.
3. Click on the purple icon for your virtual weather station and click **"select."**

NOTE: The virtual weather station will appear more visible on the map if the boxes in STEP-3 are unchecked for the personal and airport weather stations.

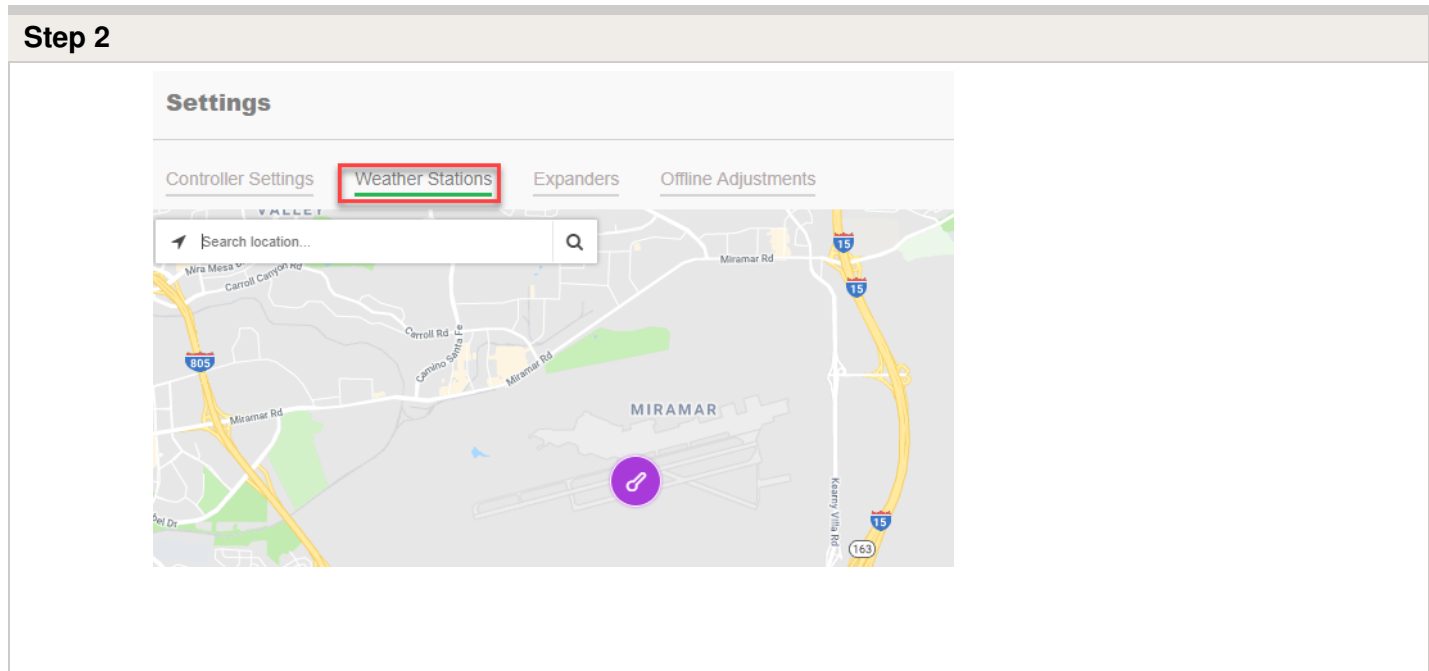
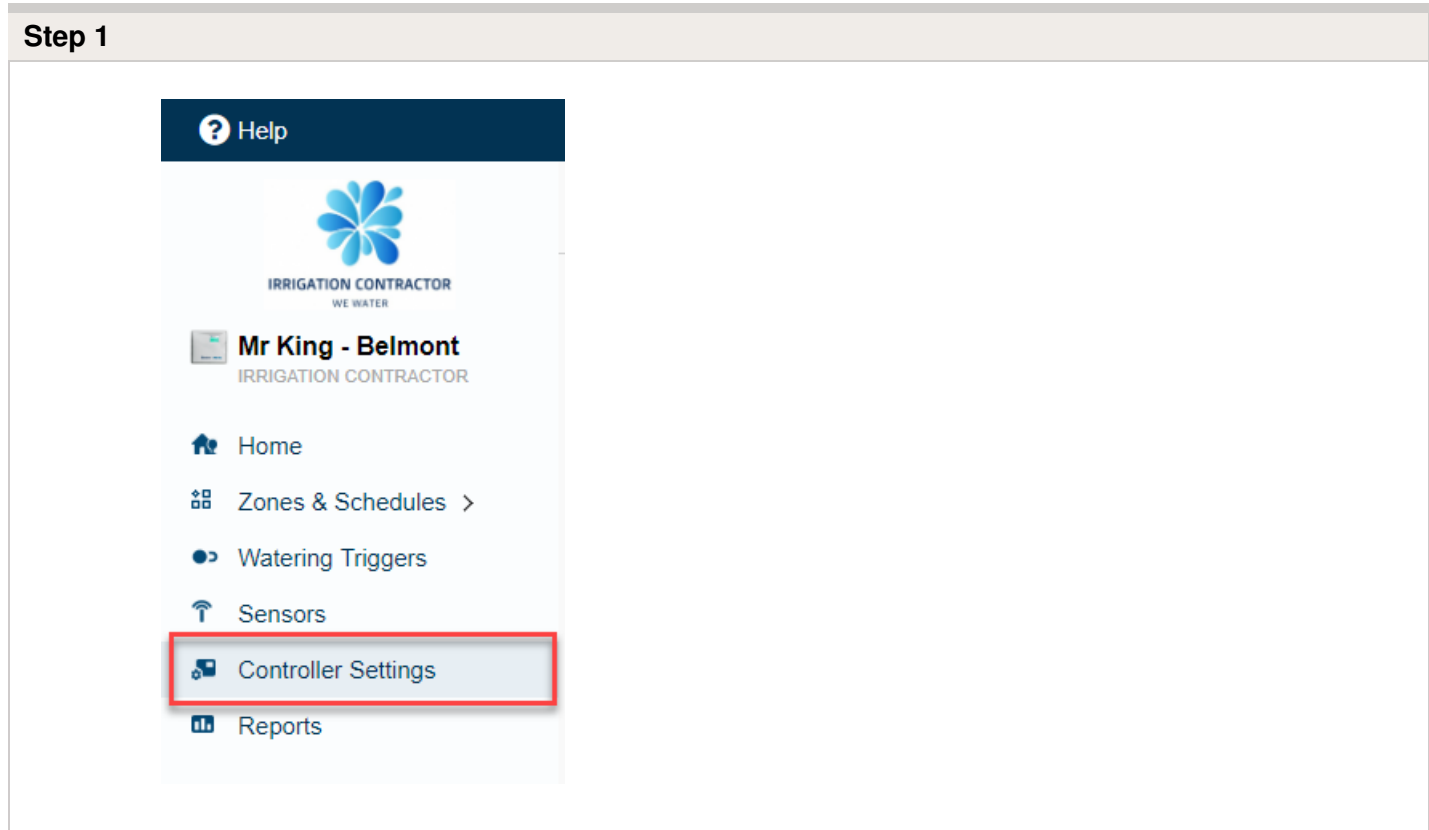

Step 3



Weather Stations

Your Enthusiast plan allows you to select up to 5 Weather Stations updated hourly. If you select multiple weather stations then your weather station readings are averaged out to give a higher degree of rainfall accuracy.



Closest Station 0.00 mi
1943 Diamond St, San Marcos, CA
92078, USA

28 Stations

- 23 Personal Weather Stations
- 4 Free Airport Weather Stations
- 1 Free Virtual Weather Station

Show weather stations not reporting temperature and rainfall

Step 4

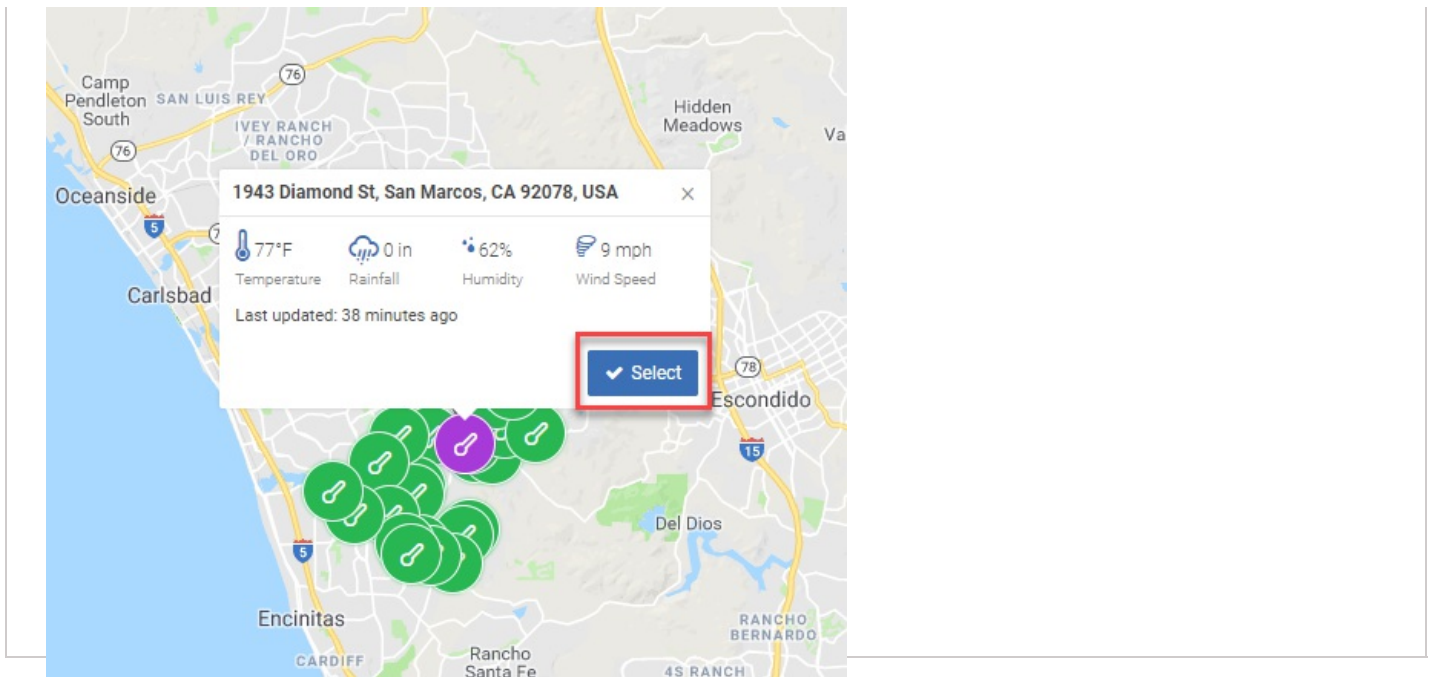

Account - Units of Measurement

For information on changing the units of measurement for your area, please see the steps below:

1. Click **"Account Details"** under the settings tab on the upper right hand side.
2. Click the  icon in the user settings box.
3. Scroll down to choose the correct units of measurement. Screenshots below:

Step 1

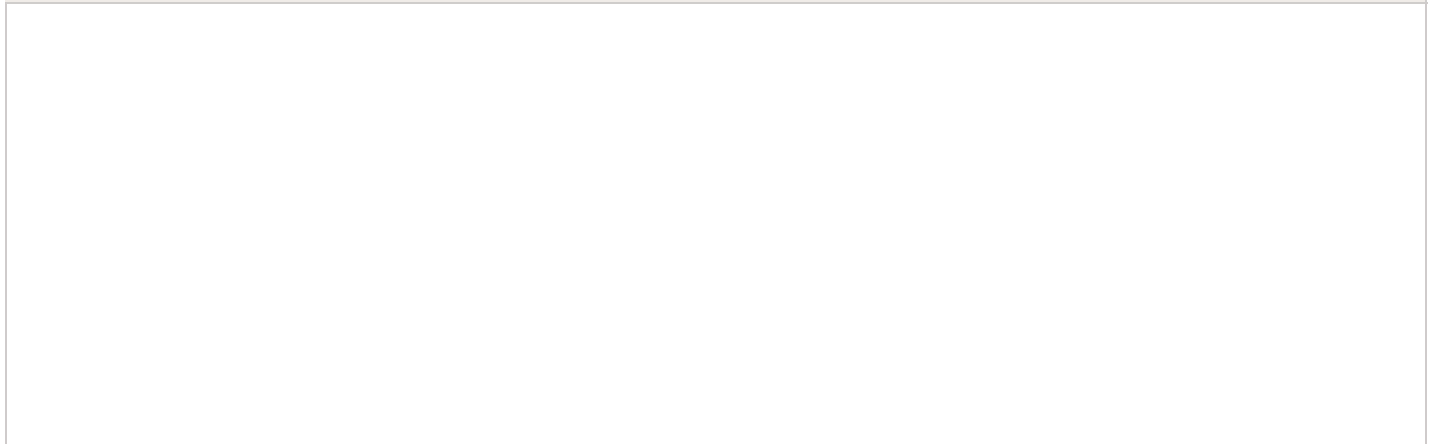

The screenshot shows a top navigation bar with icons for signal, messages, notifications, email, and user profile. Below the bar, the 'Observations' section displays 'Temperature' (Current and Max) and 'Rainfall'. A 'MY ACCOUNT' dropdown menu is open, listing 'Account Details' (highlighted with a red box), 'My Controllers', 'Users', 'My Files', and 'Logout'.

Step 2

The 'USER SETTINGS' panel shows 'UNITS OF MEASUREMENT' set to 'Celsius & Millimeters' and 'LANGUAGE' set to 'English'. The user is identified as 'Hydrawise Contractor' with email 'contractor@hydrawise.com'. A red box highlights an edit icon in the bottom right corner.

Step 3

The 'Edit User' form contains fields for 'Name' (Hydrawise Contractor), 'Email Address' (contractor@hydrawise.com), 'Units of Measurement' (Celsius & Millimeters, highlighted with a red box), and 'Language' (English). A 'Change Password' button is on the left, and 'Cancel' and 'OK' buttons are on the right.

Account - Adding a Contractor

If you have a contractor in your area where you would like them to manage or view your controller settings when necessary, please follow the steps below:

1. Click "**Account Details**" under the settings tab on the upper right hand side.
2. Click on  **icon** under privacy settings.
3. You will now have the option to **search** and **select** a contractor in your area filtered by the radius selected.

Step 1

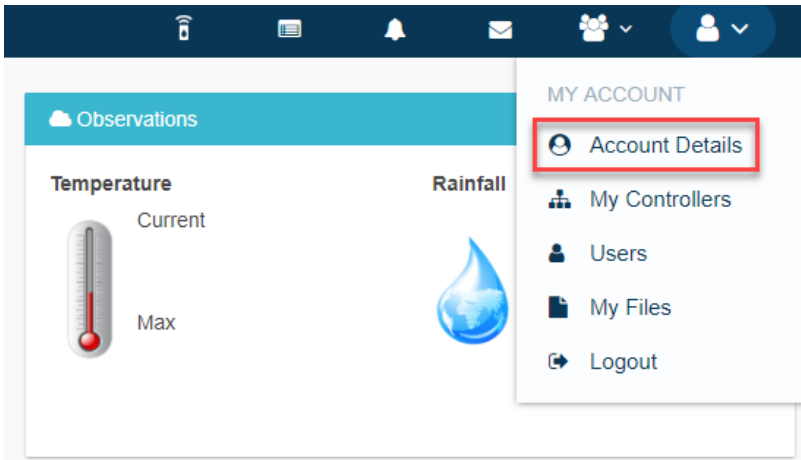

The screenshot shows a mobile application interface. At the top, there is a dark blue navigation bar with several icons: a signal strength indicator, a document icon, a notification bell, an envelope icon, a group of people icon, and a user profile icon. Below the navigation bar, the main content area is divided into two sections. On the left, there is a 'Observations' section with a teal header. Underneath, there are two sub-sections: 'Temperature' and 'Rainfall'. The 'Temperature' section shows a thermometer icon and labels for 'Current' and 'Max'. The 'Rainfall' section shows a blue water drop icon. On the right side of the screen, a 'MY ACCOUNT' menu is open, listing several options: 'Account Details' (which is highlighted with a red rectangular box), 'My Controllers', 'Users', 'My Files', and 'Logout'.

Step 2

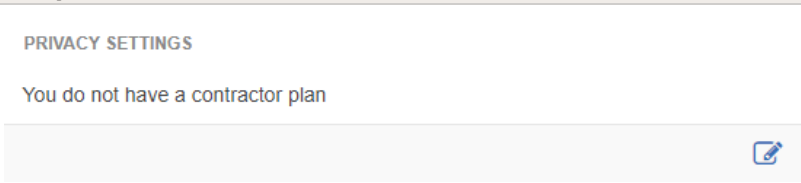

The screenshot shows a 'PRIVACY SETTINGS' screen. At the top, the text 'PRIVACY SETTINGS' is displayed. Below this, a message reads 'You do not have a contractor plan'. At the bottom right of the screen, there is a small blue edit icon (a square with a pencil).

Step 3

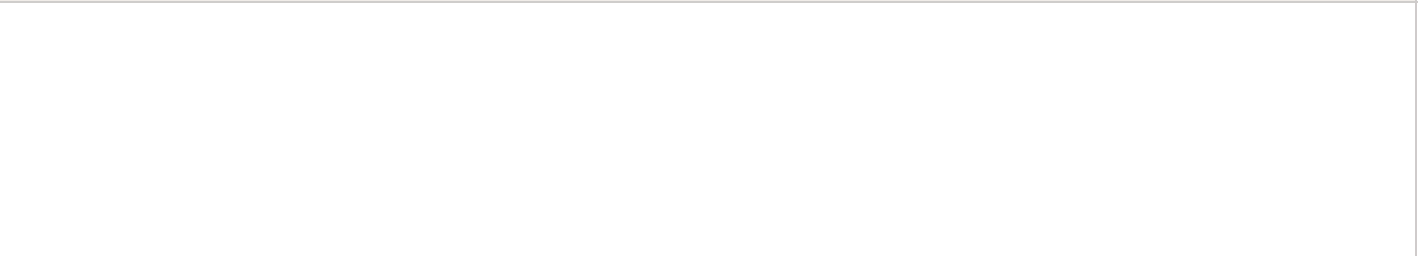

This section is currently empty, representing the third step in the process.

Contractor Selection

Filter by radius 30kms 80kms 160kms

Here are the closest **6** Hydrawise contractors to you based on your ad

Proffitt Landscapes (Your Contractor) BRONZE



 CONTACT

 LOCATION
1943 Diamond Street, San Marcos, CA, United States

[MAKE ACCOUNT PRIVATE](#)

Account - Account Name Edit

To rename the account, please view the steps and screenshots to access this feature:

1. Click "**Account Details**" under the settings tab on the upper right hand side.
2. Click on the  icon near the "**User Settings**" field.
3. Enter the new "**Name**" desired shown in the box.

NOTE: The default account name is your login name until you change it to be something else.

Step 1

The screenshot shows the mobile app interface. At the top, there is a dark blue navigation bar with icons for signal strength, Wi-Fi, notifications, email, and user profile. Below this is a white header with a teal bar labeled 'Observations'. The main content area is split into two columns: 'Temperature' with a thermometer icon and 'Rainfall' with a water drop icon. On the right side, a 'MY ACCOUNT' dropdown menu is open, listing 'Account Details', 'My Controllers', 'Users', 'My Files', and 'Logout'. The 'Account Details' option is highlighted with a red box.

Step 2

The screenshot shows the 'USER SETTINGS' page. On the left, there are two settings: 'UNITS OF MEASUREMENT' set to 'Fahrenheit & Inches' and 'LANGUAGE' set to 'English'. On the right, there is a circular profile picture placeholder, the name 'Hunter Staff', and the email address 'contractor1@hydrowise.com'. A red box highlights a pencil icon in the bottom right corner, indicating the edit function.

Step 3

The screenshot shows the 'Edit User' form. It has a title bar 'Edit User' with a close button. On the left, there is a circular profile picture placeholder and a 'Change picture' link. The form contains three input fields: 'Name' with the value 'Hunter Staff', 'Email Address' with the value 'contractor1@hydrowise.com', and 'Units of Measurement' with a dropdown menu set to 'Fahrenheit & Inches'. At the bottom, there are three buttons: 'Change Password' (blue), 'Cancel' (grey), and 'OK' (green). The 'Name' input field is highlighted with a red box.

Account - Rename Controller

To rename your controller, please view the steps and screenshots to access this feature:

1. Select "**Controller Settings**" from the home dashboard on the left hand side.
2. Once the configuration screen has loaded, click on the  icon to edit the name.
3. When you have entered the new name for your controller, click "**OK.**"

Step 1

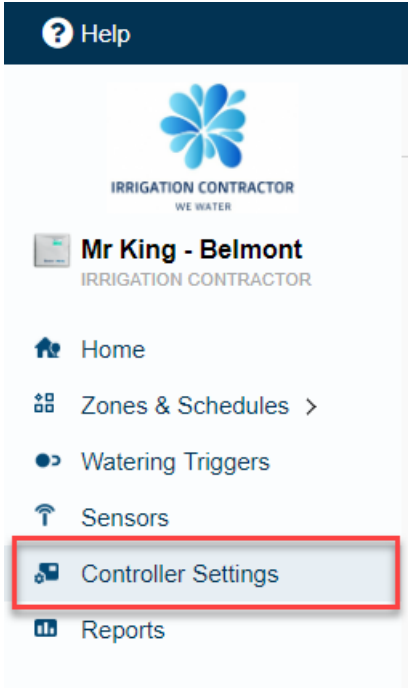

The screenshot shows the left-hand navigation menu of the Irrigation Contractor web interface. At the top is a dark blue bar with a white question mark icon and the word "Help". Below this is the company logo, a blue flower-like shape, with the text "IRRIGATION CONTRACTOR" and "WE WATER" underneath. The main menu items are: "Mr King - Belmont" (with a small controller icon and "IRRIGATION CONTRACTOR" below it), "Home" (with a house icon), "Zones & Schedules >" (with a grid icon), "Watering Triggers" (with a play button icon), "Sensors" (with an antenna icon), "Controller Settings" (with a controller icon and highlighted by a red box), and "Reports" (with a document icon).

Step 2

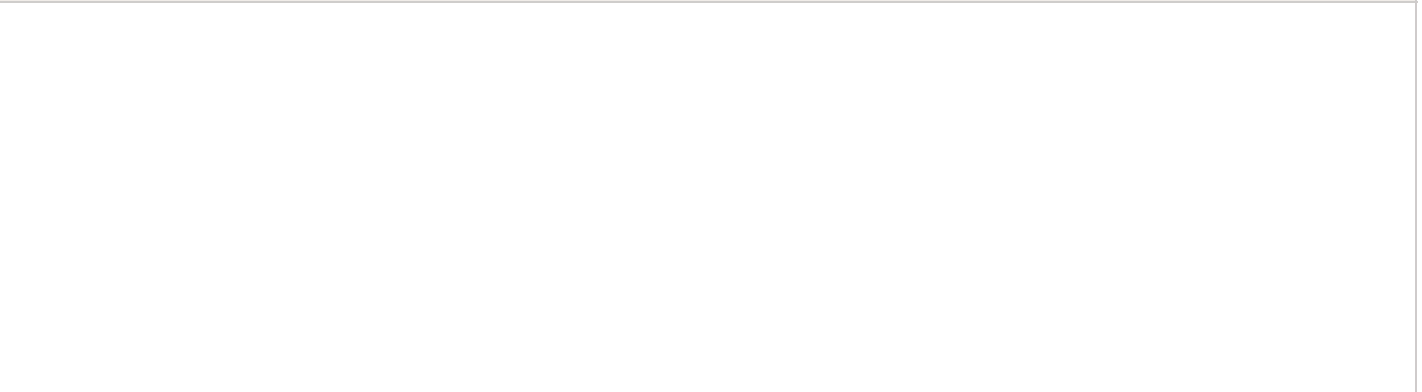



This section is currently empty, intended for a screenshot of the configuration screen for Step 2.

CONTROLLER

 NAME
Hunter Industries

 SERIAL NUMBER
virt4563 [Remove Serial](#)

 STATUS
Linked

 MODEL
HC 6 Zone Controller

 INSTALL DATE
Mon, 19 Sep 16 02:07:37 +0000

 SOFTWARE



Step 3

Edit Controller Settings ×

Name

Hunter Industries

Model

HC 6 Zone Controller [Change](#)

Cancel

✓OK

Account - Add User/Files

Add User

Both contractors and homeowners can add additional users to an account. However, as a home user, you must have an Enthusiast Plan to add additional users.

To add a user, please view the steps and screenshots to access this feature:

1. Click **"Users"** under the account settings tab on the upper right hand side.
2. Next, scroll down to **"My Account Users"** and click **"Add User."**
3. Fill in the required details and click **"Ok."** This will send a validation email to the user to activate the account. The user must create a password upon visiting the Dashboard for the first time.

Step 1

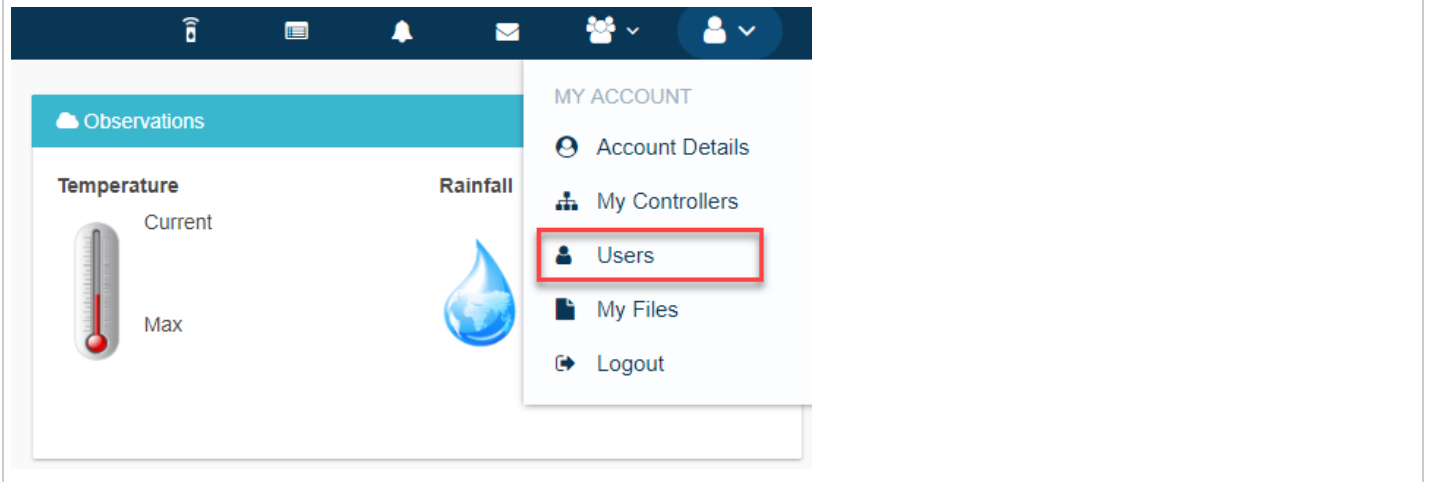

Step 2

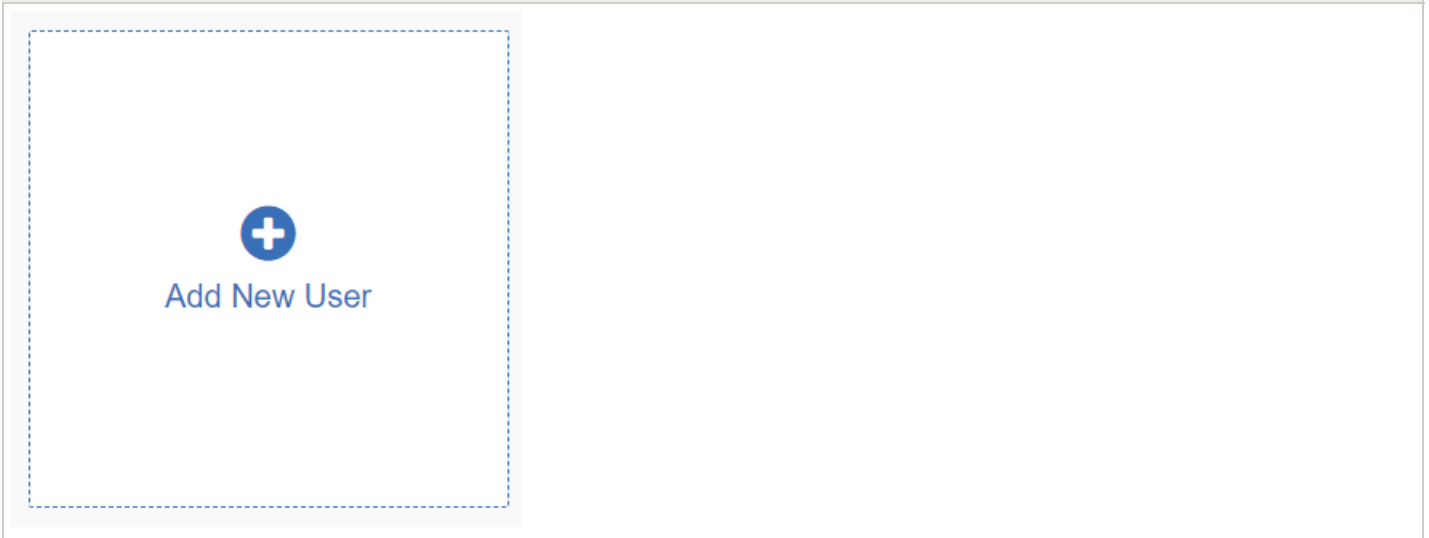

Step 3

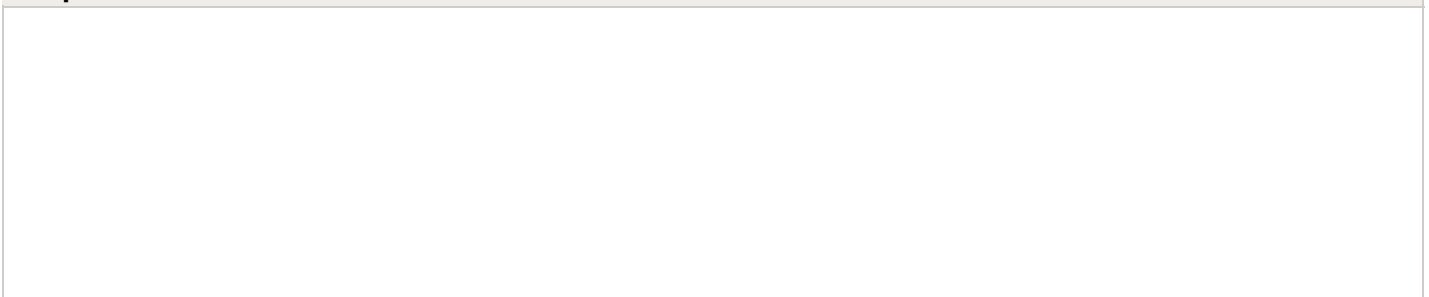

Add User
✕



Add picture

Name

Email Address

Type of User

Choose what the user can do in their account

Can modify configuration and run zones
▼

Cancel
OK

User Settings	
Add Picture	A image can be uploaded from you operating system.
User Name	The name of the new user
Email Address	The email address that the new user will use to log in to the account
Type of User	<ul style="list-style-type: none"> If you want the user to have full control over the controller, select “Can modify configuration and run zones.” If you don’t want the user to have control over configuration, select “Can view configuration, manually run zones.”

IMPORTANT You cannot add a user who already has an existing Hydrowise account. If the user has an account, email us at support@hydrowise.com ^[17]. We will delete the account from our system and you can then add the user accordingly.

Files

Towards the bottom of the accounts detail page, you can upload files which are useful in managing your garden. For example, you might like to add a picture which shows the layout of your garden and zones. Uploading of files is supported for Enthusiast plan customers.

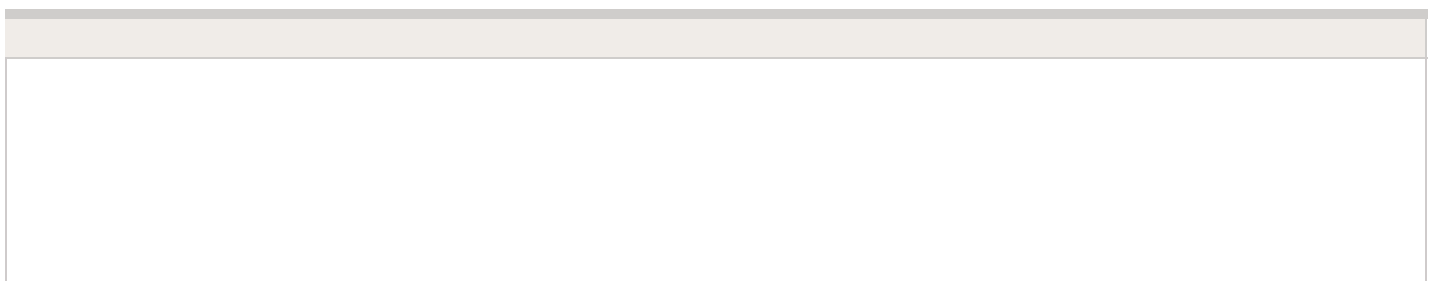

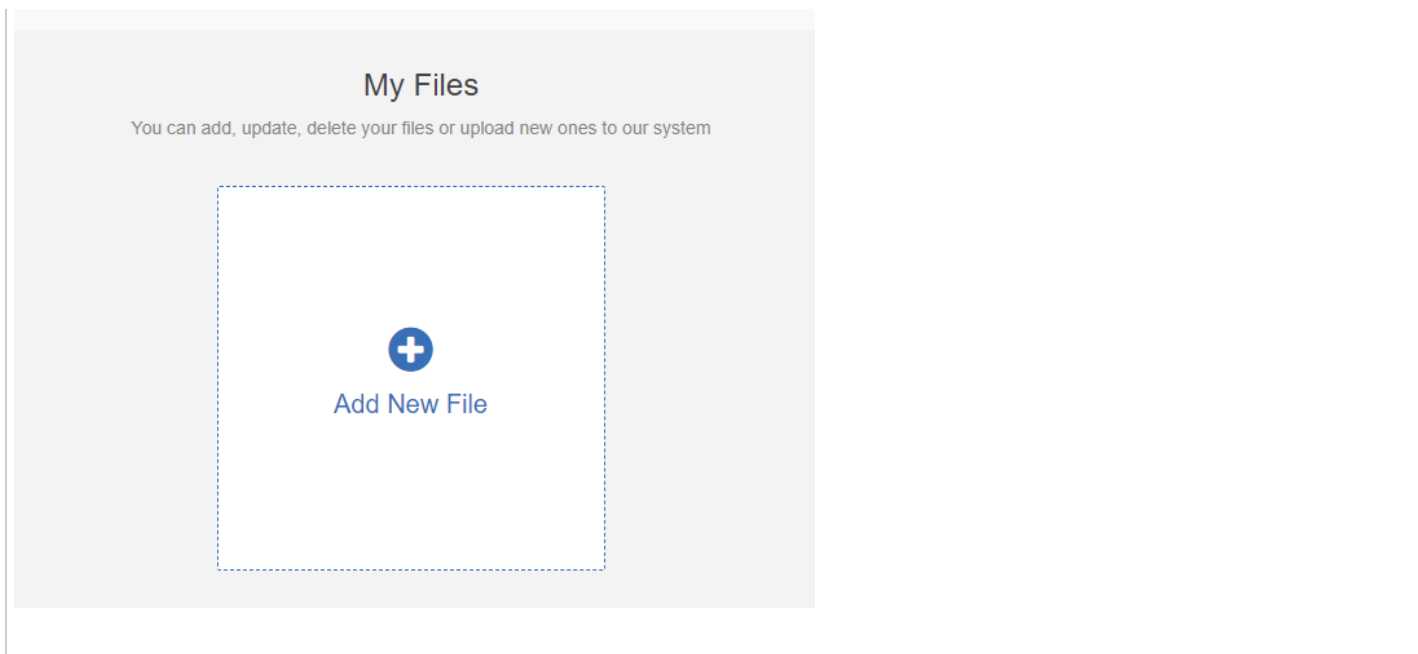



Account - Setting Delay

To set a delay between your zones (inter-zone delay) or for a master valve/pump before the zone starts (master valve delay), please view the steps and screenshots to access this feature:







1. Select "**Controller Settings**" from the home dashboard on the left hand side.
2. Next, scroll over to "**valve delays**" and click the  icon
3. Enter each "**delay**" required in seconds format and Click **OK**.

Step 1

 Help



IRRIGATION CONTRACTOR
WE WATER

 **Mr King - Belmont**
IRRIGATION CONTRACTOR

-  Home
-  Zones & Schedules >
-  Watering Triggers
-  Sensors
-  **Controller Settings**
-  Reports

Step 2

REGIONAL SETTINGS

 TIMEZONE
America/Los_Angeles



VALVE DELAYS

 INTER ZONE DELAY
0 seconds

 MASTER VALVE DELAY
0 seconds



Step 3

Edit Valve Delays
✕

Inter Zone Delay

seconds

Master Valve Delay

seconds

Cancel
✔OK

Delay	Description	Max Delay
Inter-Zone Delay	The number of seconds between each of the zone run times.	3,600 Seconds
Master Valve Delay	The minimum number of seconds that the master valve should be active before any zone starts. Hydrawise on shut down always shuts the station valve 1 st and then about 1 second later shuts the master valve.	600 Seconds

Some watering systems require water pressure for a sprinkler head to pop up. This delay can be used to ensure that water pressure is built up or maintained before a zone starts watering (or before the next zone begins watering) by delaying the time the next valve opens, ensuring water pressure is present. Depending on your specified setup, these delays can be used to meet those requirements.

Account - Exporting Reports

The instructions below will allow you to download the report chosen into an Excel document.

To download your reports in Excel, click on the **Reports Tab** on the left hand side of the home dashboard. After highlighting one of the download options listed below, you can click the download tab to automatically save to a excel file on your computer.

Download Options Include:

1. Day
2. Week
3. Month

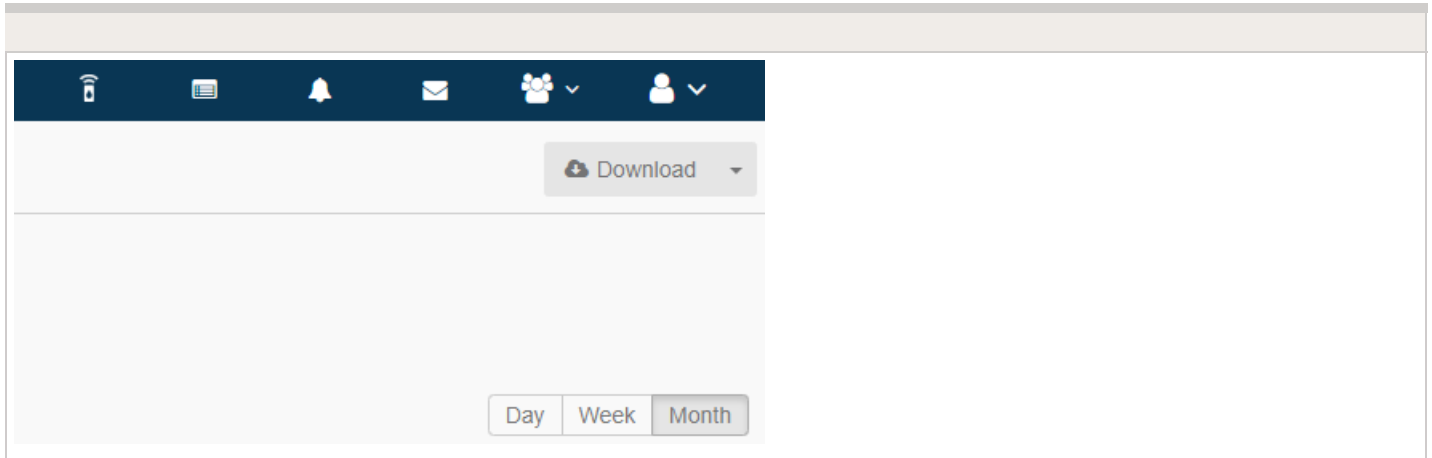

NOTE: The free Home Plan provides up to 30 days of reporting, and the Enthusiast Plan provides up to 365 days of reporting.

Account - Moving Serial Number

This article will cover the following information on editing your controller's serial number.

1. Unlink controller from your account
2. Linking to your account (Setup wizard and Dashboard)

Unlink From Account

This is important if you wish you resell your controller or want to transfer ownership to someone else. This prevents the next user from getting the error message that the serial

number they are trying to link to their account is already in use.

To unlink a controller, follow the steps below:

1. Select "**Controller Settings**" from the home dashboard on the left hand side.
 - From your smartphone app, click on "**More**" then click on **Configuration**.
1. On the next screen, locate your serial number. Then click "**Remove serial.**"

Step 1

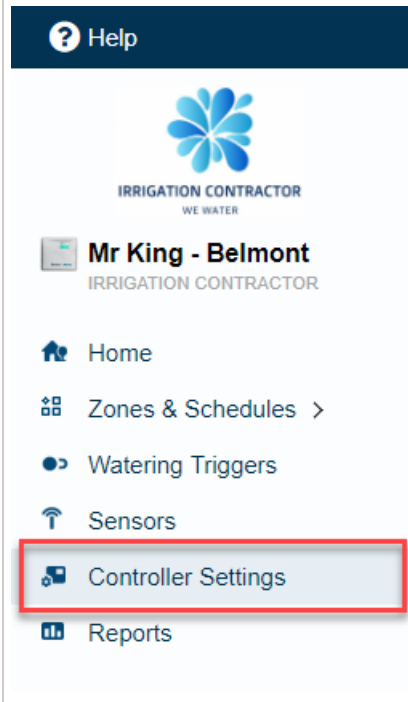

Step 2

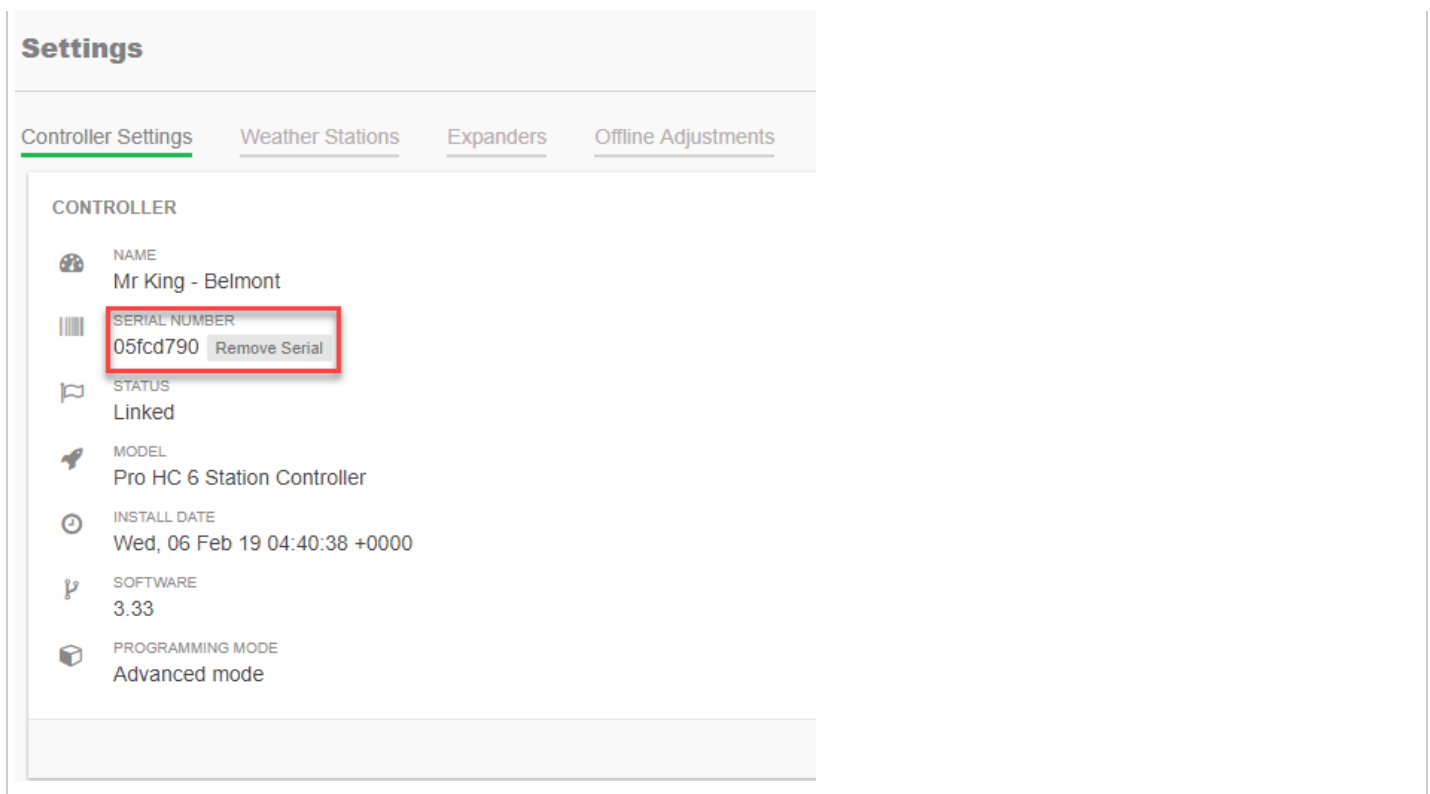

NOTE: This is helpful if you are either using controller on another site or replacing under warranty.

Linking to Your Account

There are two locations where you can link your controller to your account:

- During the setup wizard (optional)
- From the controller **Dashboard**

NOTE: You only need to link your controller to your account once. If you provided a serial number when going through the setup wizard, you've successfully linked your controller to your account and you can ignore these instructions.

To link your controller through your account Dashboard, follow these steps:

- [Log in to your account](#) ^[8].
- On the Dashboard, click on the Settings icon located on the blue Watering Schedule bar. Then click the **Link to controller...** button.
- Enter your controller's serial number. The eight-character serial number is found on the side of the unit. The serial number is not case-sensitive.

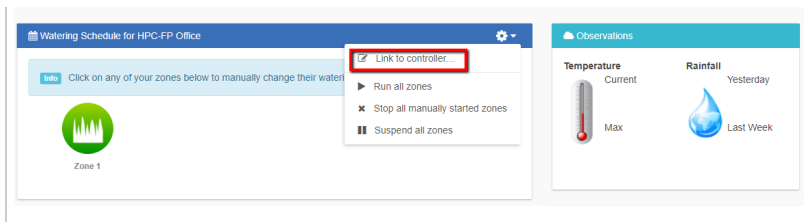

Once you've entered the serial number, your controller will automatically download your settings and begin watering based on your watering schedules.

Account - Resetting Password

If you registered using your email address (i.e., not using the Facebook option), click on **Forgot password?** from the [login](#) ^[8] screen.

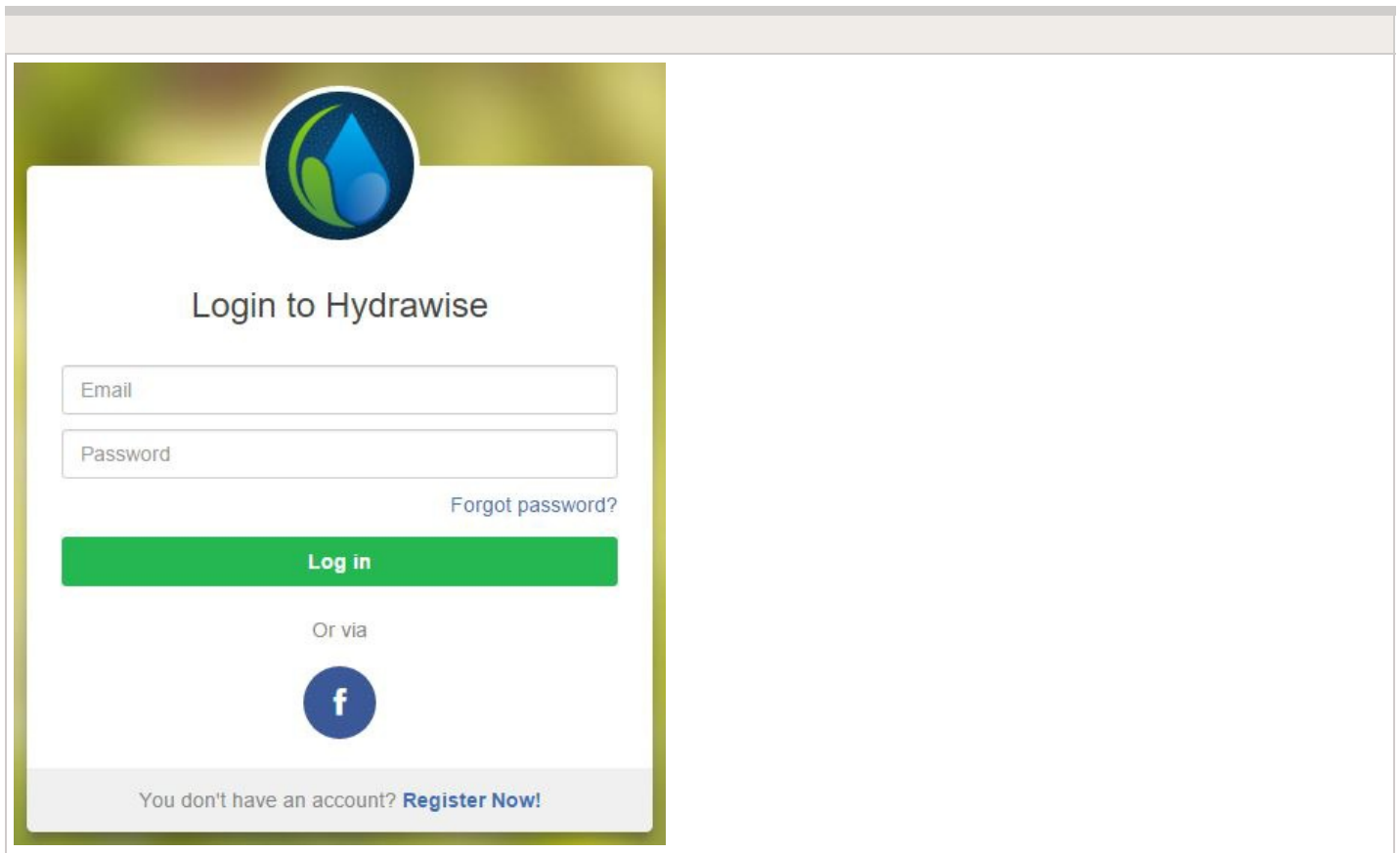

On the next screen, simply type in your registered email address and click **Reset Password**. You will then receive an email. Click the password reset link and enter in your new password. Confirm the password and you should be good to go again.

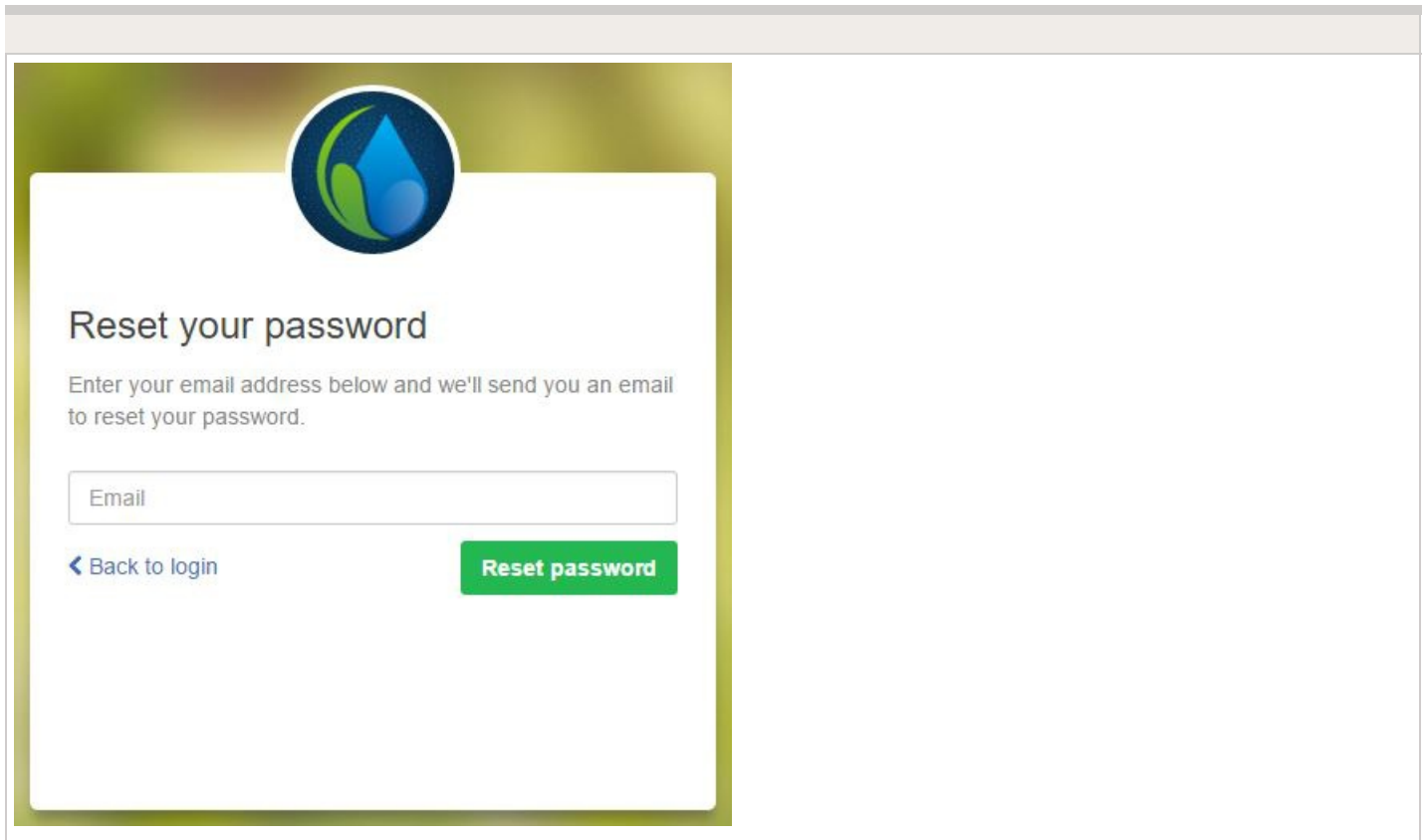

Reset your password

Enter your email address below and we'll send you an email to reset your password.

Email

[Back to login](#) **Reset password**

If you are having issues logging in to Facebook using the application, follow this guide to reset your password: [Unable to Log In Using Facebook App](#) ^[18]. Don't worry; you won't lose any settings.

Account - Not Receiving Hydrawise Activation Emails

We're sorry that you have not yet received an activation email from

support@hydrawise.com ^[19]. We use a third-party company to ensure our email has the best chance of getting to you.

The following tips will help you verify if the email was delivered. First, check your deleted items to see if the email was inadvertently deleted. If it was, move the email back to your inbox.

Next, look in your spam, trash, or junk folders. The email may have been sent to one of these folders due to email filters. If the email is in one of these folders, right click on the email and select “trust sender” or “always allow email from sender.”

We recommend that you add support@hydrawise.com ^[19] to your “safe senders,” “allowed,” or “trusted” email list. Depending on your email service provider, you can do this in several ways. Below are shortcuts to some popular providers:

[Outlook](#) ^[20]

[Gmail](#) ^[21]

[Apple](#) ^[22]

Hydrawise does not use your email address for marketing purposes. To view our terms and conditions and privacy policy, visit www.hydrawise.com ^[23]. Please contact us if you have questions.

Configuring - Several Watering Lengths One Zone

You will now learn how to achieve different watering times using one zone (or many zones, if you understand the concept of stacking start times).

Stacking start times means creating Program Start Times one after the other based on the duration of the watering length set for each zone.

For example, if you wanted Zone 1 to run for 10 minutes in the morning and 30 minutes in the evening, you would have to set up Zone 1 with a watering length of 10 minutes. Then you would use Program Start Times to achieve the watering times you want.

NOTE: You must use “Every Valid Program Start Time” to achieve this goal, as the Program Start Time dictates when the zone is allowed to water.

A typical zone would be set this the example below:

Example 1

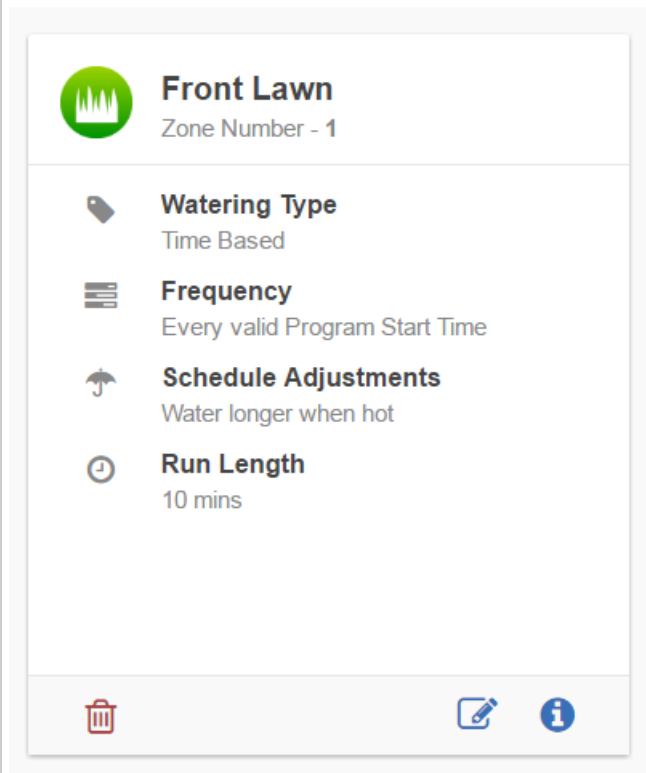

The screenshot shows a control panel for a zone named "Front Lawn" (Zone Number - 1). The panel includes the following settings:

- Watering Type:** Time Based
- Frequency:** Every valid Program Start Time
- Schedule Adjustments:** Water longer when hot
- Run Length:** 10 mins

At the bottom of the panel, there are three icons: a red trash can, a blue pencil (edit), and a blue information icon.

To water for 10 minutes in the morning, you would create one start time at 7 a.m., for example, that allows Zone 1 to run for 10 minutes.

Example 2

This section is currently blank.

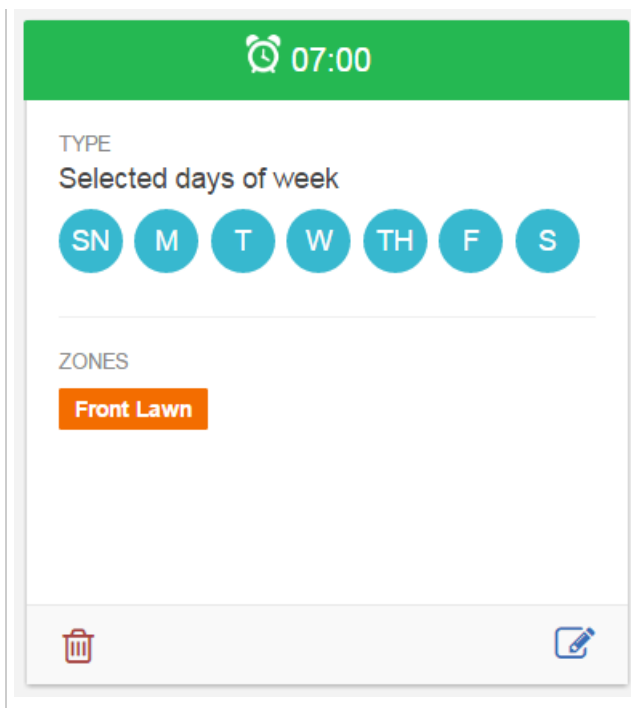

For Zone 1 to run for 30 minutes in the evening, you will need to stack start times. For example, you will need to create program start times for Zone 1 at 7 p.m., 7:10 p.m., and 7:20 p.m., so the zone runs for a total of 30 minutes.

Example 3

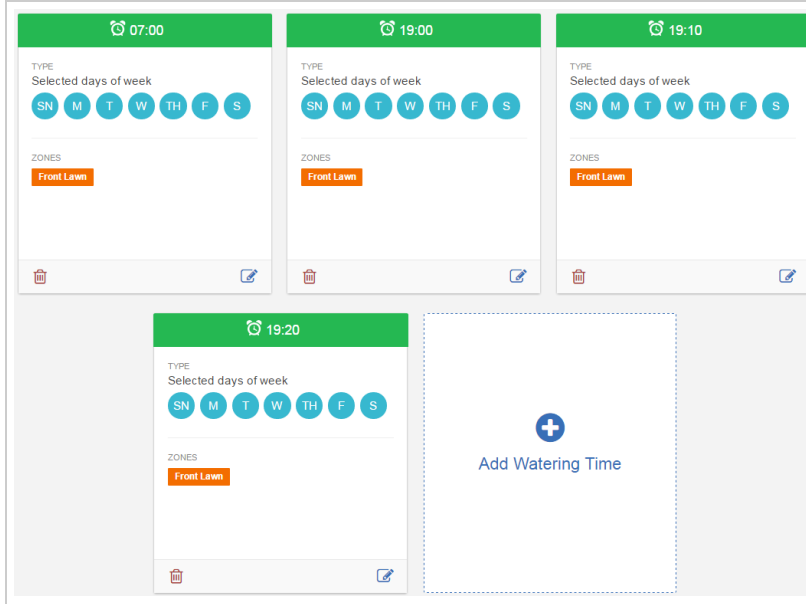

By having the program start times dictate when zone one is allowed to water, we have achieved 10 minutes of watering in the morning and 30 minutes of watering in the evening without modifying the irrigation zone's configuration. See below for what the schedule will look like.

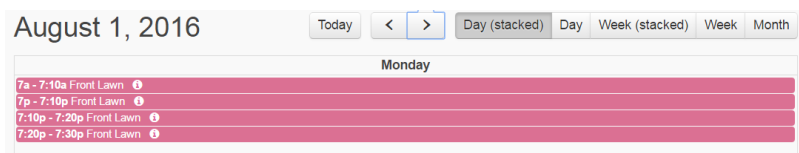

You can see there are 10 minutes of watering at starting at 7 a.m. Then, starting at 7 p.m., there is a total of 30 minutes of watering as a result of stacking your Program Start Times.

IMPORTANT: This method only applies with **Predictive Watering™** and will not work with Smart Watering. The water trigger "[Water More Often When Hot](#) [24]" will not also work if you want to use this method, as it uses "Every Valid Program Start Time."

Configuring - Trigger "Water More Often When Hot"

The "**water more often when hot**" feature will allow the end user to water a second time based on the current climate condition of the temperature reading. This is only available when using **Time Based Watering type**. Please view the steps and screenshots to access this feature:

Click on "**Zones and Schedules**" from the home dashboard. Scroll down to the first zone you choose to edit. Click on the  icon.

1. Choose the watering type "**Time Based Schedule**" and click "**next.**"
2. Change the watering frequency to "**interval based watering**" interval one.
3. Check the box for "**Water more often when Hot.**"
4. Choose "**ok**" to complete this setup.

Step 1

Zone Details ▶ **Time Based Schedule** ▶ Cycle & Soak ▶ Advanced

Zone Name
Assign a name for this irrigation zone
Zone 1

Zone Number
Choose the zone number that this zone is wired to on your Hunter controller
Zone 1

Zone Icon
Choose the icon you want to see on the dashboard for this zone

Watering Type
 Time Based Schedule Smart (ET) Schedule Virtual Solar Sync™
 Water at a specified frequency (eg. every 1 week) and adjust schedule based on temperature and rainfall

Cancel < Prev **Next >** ✓ OK

Steps 2-4

Zone Details ▶ **Time Based Schedule** ▶ Cycle & Soak ▶ Advanced

Watering Type
 Enter Time and Frequency below
 Use a Preconfigured Watering Schedule

Watering Length
The number of minutes this zone will run for each time
5 minutes

Watering Frequency
Choose how often this zone should run
 Every Program Start Time Interval Based Watering
 1 days

Predictive Watering™
Adjust watering based on the following triggers
 ⚙️ Don't water when:
 Forecast below 60°F 80%+ chance of rain
 Wind above 62mph 0in+ rainfall last day
 3in+ rainfall last 7 days
[Edit monthly adjustments \(advanced\)](#)

✎ Adjust watering:
 Water 30% less when below 73°F
 Water longer when hot
 Water more often when hot

Cancel < Prev **Next >** ✓ OK

Scroll to bottom of **"zones and schedules"** to create a 2nd start time.

1. Choose the plus sign for **"Add watering Time."**
2. Choose a **"second start time"** and click **"next."**
3. Make sure you apply to the correct zones and click **"ok."**
4. In the **"water trigger"** section, set the one trigger highlighted accordingly.

IMPORTANT: Make sure you have all zones selected for the start times created (or, at the very least, the zone you intend to "Water More Often When Hot").

Program Start Time

Watering Program Start Times are listed below. These times specify when your controller is permitted to

5:00am

TYPE
Normal watering time (every week)

SN M T W TH F S

ZONES
All Zones

+

Add Watering Time

Step 2

Set Time | Select Zone

Start Time
Enter the time for this Program Start Time
06:00 PM

Watering Type
Normal watering time (every week)
Normal watering is permitted to start at this time

Watering Days
Select the days of the week to water
Selected Days of the week
SN M T W TH F S

Cancel < Prev **Next >** OK

Step 3

Set Time ▶ **Select Zone**

Select Zones

Applies to all zones ▼

This program start time can be used by all zones

Cancel < Prev Next > **OK**

Step 4

Predictive Watering™ Adjustments

Manage your watering based on weather forecasts. Choose which adjustments to apply when editing a zone.

60 F

Don't water when today's forecast temperature is less than

0 F 130 F

73 F

Water 30% less when today's forecast temperature is less than

0 F 130 F

90 F and humidity is below 100%

Water 100% more when today's forecast temperature is above

0 F 130 F

80 %

Don't water when the chance of rain is higher than

0 % 100 %

62 mph

Don't water when today's forecast wind speed is higher than

0 mph 62 mph

You can set the trigger up however you like. See below for this example:

When you check your **Watering Schedule** on the days that meet your watering triggers, extra watering will occur. For example, you will notice all watering that has been set to start at 6p.m. is "extra watering due to temperature."

Setting your frequency affects how this feature works. For it to work correctly, you must always have an extra program start time that is above your watering frequency. In our example, we used "water once a day" and created two program start times so extra watering can occur once. If you want to change this, you must ensure the above is met. For instance, if you have set watering to twice a day, you must create three program start times for the third program start time (the extra watering schedule) to take effect.

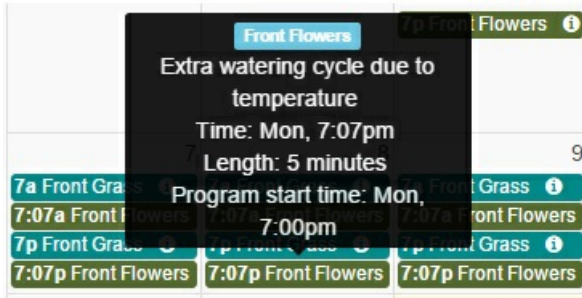

NOTE: Due to changes made to this setup, the extra zones do not show on the above screenshot because those are passed events on my watering schedule. At this time, due to weather changes, no extra watering has been scheduled. Thus, only past events were used in this example.

IMPORTANT: To ensure that "Water More Often When Hot" works, you need to have an extra program start time that is above your watering frequency. If you select "Every Available Program Start Time" as a watering frequency, this feature will not work because watering is already scheduled for all program start times.

The general calculation is:

<number of times per day> multiplied by (1 + <trigger percentage>) = number of watering times for the day (rounded down)

So, for once a day and a 50% trigger, the calculation is:

$$1 \times (1 + 0.5) = 1.5 = \text{once a day (rounded down)}$$

Twice a day multiplied by (1 + trigger percentage) could be greater than 2 if the percentage is greater than 50%:

$$2 \times (1 + 0.5) = 3 = 3 \text{ times a day}$$

Twice a day multiplied by (1 + trigger percentage) with a trigger percentage of 100% would give you 4 times a day:

$2 \times (1 + 1) = 4 = 4$ times a day

IMPORTANT: If you require multiple watering's per day, this is the one situation where low-priority watering times are useful. You could have a normal watering time of 6 a.m. and 6 p.m. and a low-priority time of 12 p.m., which will get used only if you are watering more often and you need a third cycle for the day.

Please feel free to test this setup as you see fit for your watering needs. Should you have further questions, send an email to support@hydrawise.com [17].

Configuring - Trigger "Water Longer When Hot"

The "**water longer when hot**" feature will allow the end user to water the zone longer based on the percentage set in the water trigger. This is only available when using **Time Based Watering type**. Please view the steps and screenshots to access this feature:

Click on "**Zones and Schedules**" from the home dashboard. Scroll down to the first zone you choose to edit. Click on the  icon.

1. Choose the watering type "**Time Based Schedule**" and click "**next.**"
2. Check the adjust watering feature "**water longer when hot**" and click "**ok.**"

STEP 1

Zone Details ▶ **Time Based Schedule** ▶ Cycle & Soak ▶ Advanced

Zone Name
Assign a name for this irrigation zone
Zone 1

Zone Number
Choose the zone number that this zone is wired to on your Hunter controller
Zone 1

Zone Icon
Choose the icon you want to see on the dashboard for this zone



Watering Type
 Time Based Schedule
 Smart (ET) Schedule
 Virtual Solar Sync™
 Water at a specified frequency (eg. every 1 week) and adjust schedule based on temperature and rainfall

Cancel < Prev **Next >** ✓ OK

STEP 2

Zone Details ▶ **Time Based Schedule** ▶ Cycle & Soak ▶ Advanced

Watering Type
 Enter Time and Frequency below
 Use a Preconfigured Watering Schedule

Watering Length
The number of minutes this zone will run for each time
5 minutes

Watering Frequency
Choose how often this zone should run
 Every Program Start Time
 Interval Based Watering

Predictive Watering™
Adjust watering based on the following triggers

Don't water when:

- Forecast below 60°F
- Wind above 62mph
- 3in+ rainfall last 7 days
- 80%+ chance of rain
- 0in+ rainfall last day

Adjust watering:

- Water 30% less when below 73°F
- Water longer when hot**
- Water more often when hot

[Edit monthly adjustments \(advanced\)](#)

Cancel < Prev **Next >** ✓ OK

Setting Trigger

1. Click on the default "100%" from the top right water trigger.
2. Adjust the "percentage" needed to water more and click "ok."
3. Click "Submit."
4. Using the slide bar, choose the "temperature" threshold.

NOTE: As an example, the zone using this trigger will water 15% longer when the temperature outside is above 85 degrees.

Setting Trigger: STEPS 1-3

redictive Watering™ Adjustments

ed on weather forecasts. Choose which adjustments to apply when editing a zone.

The interface consists of two panels. The left panel, titled 'redictive Watering™ Adjustments', shows a temperature trigger set to 73 F. The text reads 'Water 30% less when today's forecast temperature is less than 73 F'. A slider below the temperature is set to 73 F, with 0 F on the left and 130 F on the right. A green toggle switch is turned on. The right panel shows a temperature trigger set to 90 F and a humidity trigger set to 100%. The text reads 'Water 100% more when today's forecast temperature is above 90 F and humidity is below 100%'. A slider below the temperature is set to 90 F, with 0 F on the left and 130 F on the right. A green toggle switch is turned on. A 'Cancel' button and a 'Submit' button are visible at the top of the right panel.

Setting Trigger: STEP 4

redictive Watering™ Adjustments

ed on weather forecasts. Choose which adjustments to apply when editing a zone.

The interface consists of two panels. The left panel, titled 'redictive Watering™ Adjustments', shows a temperature trigger set to 73 F. The text reads 'Water 30% less when today's forecast temperature is less than 73 F'. A slider below the temperature is set to 73 F, with 0 F on the left and 130 F on the right. A green toggle switch is turned on. The right panel shows a temperature trigger set to 85 F and a humidity trigger set to 100%. The text reads 'Water 15% more when today's forecast temperature is above 85 F and humidity is below 100%'. A slider below the temperature is set to 85 F, with 0 F on the left and 130 F on the right. A green toggle switch is turned on.

Smart Watering - Quick Reference

How Does it Work?	Description
When does it water?	Waters when estimated moisture level reaches 0% in zones and schedules.
Choosing Run Times	See run time calculator here [25] or consult with local contractor/distributor.
How is ET calculated?	The calculation is done through the run times and the last 10 years of ET history based on the hottest time of the year for that location.
Forecasting High Temperature	Forecast three days in advance.

Programming: Zones and Schedules	Description
Enter Watering Length	Enter the number of minutes you want the zone to run (hottest time of the year)
Enter Peak Watering Frequency	Enter the time between watering in the peak of your irrigation (hottest time of the year) Example: 1 day interval means the system will water every day in the summer schedule.
Next Available Start Time Box	Checking this box will reset the smart water balance to 0. If this box is not checked when changing from time based to smart watering then the bar will automatically be at 100%.
	This helps reduce runoff by running small increments with same total run time. This is used instead of soil type and slope. <i>Example:</i> Station 1 requires 20

Cycle/Soak	<p>minutes of watering, but after 5 minutes, runoff occurs. However, after 10 minutes all the water is absorbed.</p> <p>The solution would be to program 20 minutes for the station run time, 5 minutes for the Cycle time, and 10 minutes for the Soak time.</p>
Advanced	<p>Fine tuning: This feature is designed to slow down or speed up the drying process. If the soil is too wet, then we allow it to dry for longer, too dry, smart watering will allow less drying time.</p>

Example: If we have every 2 days set as the frequency, this is not the minimum frequency as it is merely a reference point based on the driest time of the year. If we experience a drier time, we may need to water each day. Likewise, if we have a wetter time the frequency will increase, allowing for more time between watering.

Water Triggers	Description
Use forecast temperature to predict Smart Watering	This trigger allows frequency adjustment based on the current season.
Use forecast rainfall to delay Smart Watering	This feature assists in delaying irrigation when rain is predicted.

Smart Watering - Adjustment and Changes

Smart Watering is an automated watering schedule that uses information about environmental conditions to ensure your plants get the optimum amount of water. Evaporation will draw moisture from your garden, while rainfall and irrigation will add moisture. Understanding these conditions allows Hydrowise to decide when the time is right to water your garden.

NOTE: This calculation occurs in the background and may not always be reflected when checking reports or

viewing your **Dashboard**. However, the feature does work and is reliable even if you can't visibly see these calculations.

In this example, there are two Smart Watering zones highlighted in red:

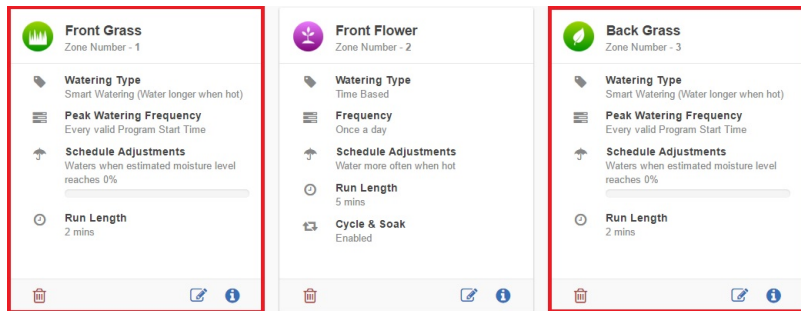

The **Watering Triggers** use Smart Watering Adjustments and have been left as default, with both switched on:

NOTE: If you turn off "Use forecast temperature to predict Smart Watering," your Smart Watering zones will not water. This is because all calculations have been switched off, and Smart Watering is calculated using weather data to predict estimated soil moisture balance. You can use this feature when you don't want any watering to occur without having to suspend your Smart Watering zones.

The second option, "Use forecast rainfall to delay Smart Watering," assists with delaying irrigation when rain is predicted. Refer to the example below to see how this is affected when it is turned off.

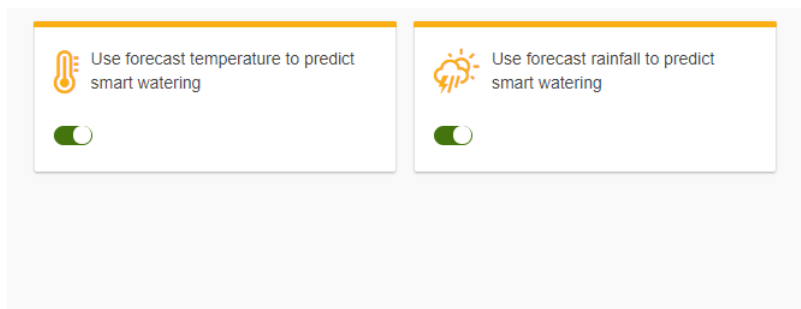

This is what your watering schedule will look like with these settings are combined with the weather forecast from your selected weather station.

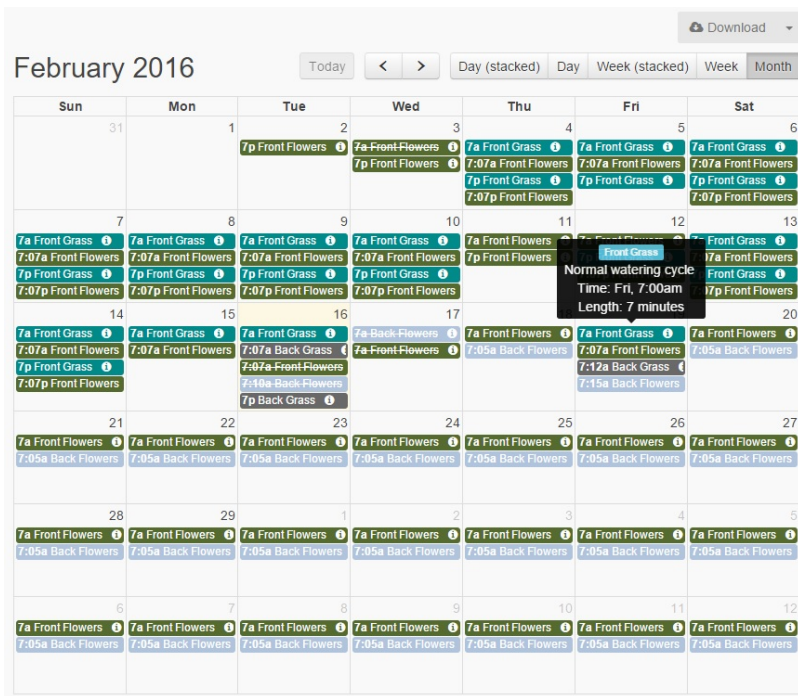

Now if we are to change the watering trigger on the second option to off as shown below:

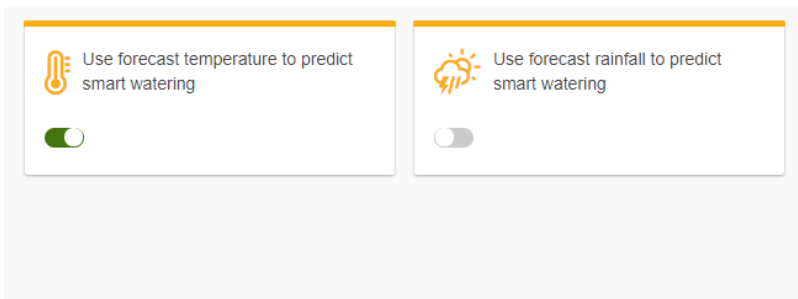

You will notice when checking your watering schedule that it has been changed to water a day earlier on both zones. This is because the trigger "Use forecast rainfall to delay Smart Watering" is on (this is based on the calculations from the weather station; there is rain predicted on 18th). It has not been scheduled to water on that day, and watering has been pushed to the 19th. However, since we turned off this feature, watering will occur regardless if rain is predicted.

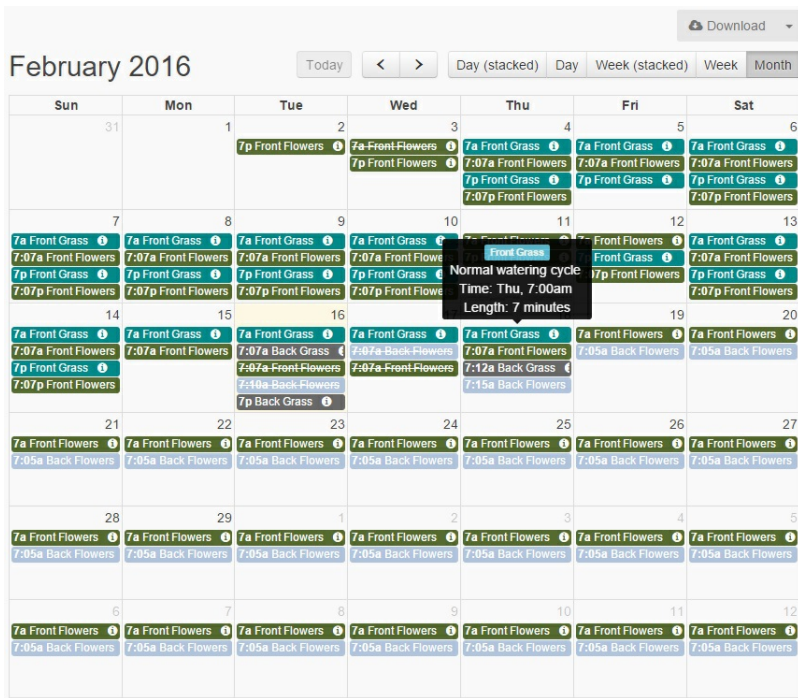

IMPORTANT: Some things to keep in mind when using Smart Watering:

Remember that Smart Watering schedules are based on estimated soil moisture balance and how you specify the watering length and peak watering frequency. Thus, the higher your estimated soil moisture balance, the less likely a smart watering zone will be scheduled to water. More importantly, please remember that Smart Watering only forecasts three days in advance. If there is no watering scheduled during the next three days, you will see **Not Scheduled** next to **Next Run** when you highlight over your Smart Watering zone on your dashboard.

- If you choose to change the watering time, you can always go to the tuning tab on any zone for both Smart Watering and Time-Based **Predictive Watering™** to modify watering length as shown below:

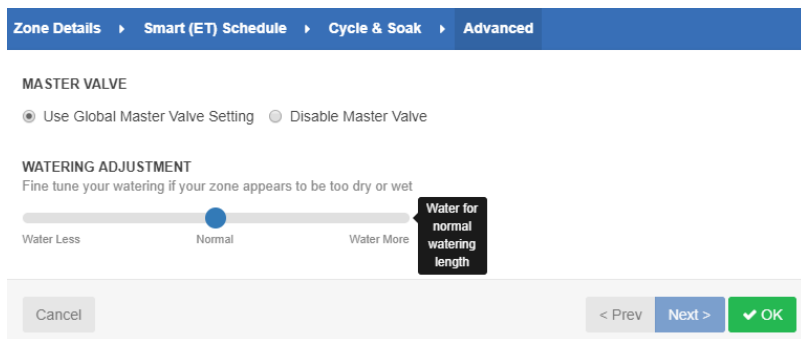

Please refer to the link above to gain further understanding of smart watering, if needed. If you have further questions regarding this feature, email us at support@hydrawise.com [17].

A final note: Although both Smart Watering and time-based **Predictive Watering™** achieve similar water savings due to “predictive weather” watering triggers, time-based watering is easier to understand and adjust.

Offline Mode - Accessing Offline Mode

Offline Mode

If the controller loses its internet connection for more than 24 hours, you'll receive a notification email. The controller will then go into offline mode. In offline mode, your controller won't be able to access local weather conditions such as rainfall or evaporation. As a result, it will revert to a predefined program.

- For **Smart Watering** zones, the controller will adjust each zone's watering length based on your offline watering budget and will water at each zone's configured peak watering frequency.
- For **Time-Based Watering** zones, the controller will adjust each zone's watering length based on your offline watering budget and will water at each zone's configured watering frequency.
- Note that **Cycle and Soak** is not supported in offline mode and each zone will water for its full watering length without pausing.
- The controller will only water at your configured **Program Start Times**.

To set your controller to **offline Mode** for manual configuration, please follow the steps below:

1. From the main menu, tap on **Settings**.
2. Tap on **Offline Settings**.
3. Tap on **Disable Wi-Fi**.
4. You will be presented with a warning dialogue. Please make sure you understand the warning before proceeding. If you're sure that you want to go offline, tap **Go Offline**.
5. Now that your controller is in Offline Mode, you can configure it manually by tapping on **Program Start Times**.
6. From this screen, you can manually configure each zone according to your desired schedule. Simply tap on **Add** to add a program start time and follow the steps below. You can toggle between zones by tapping on **Next/Previous** or you can leave the start time to **APPLY to ALL ZONES**.

Applying the start time to **ALL ZONES** will run through all zones with a single start time.

1. Tap **ADD** in the start times menu.
2. Select the green box upper in left to enter **PROGRAM START TIME (24 hr format)**
3. Tap the **DAYS** to be selected **after** finished with start time entry.
4. Tap **CONFIRM** to save the start time entry.
5. Add a second start time for all zones or single zone if desired.
6. Tap the **HOME** icon (upper right) to allow station run times setup.

NOTE: Each zone can have up to four program start times and an additional four start times under the **All Zones** section as shown below.

7. From the home screen, you can manually configure each zone run time. Simply tap on **ZONES** to add a zone run time and follow the steps below. You can toggle between zones by tapping on **each zone number**.

1. Tap **ZONES** in the home menu.
2. Tap the first zone to edit, (**For Example: ZONE 1**).
3. Tap on **RUN TIME** in the center of the screen.
4. Enter **RUN TIME (minutes:seconds format)**, then press **OK** to save entry.
5. Repeat steps **1-4** for station run times.

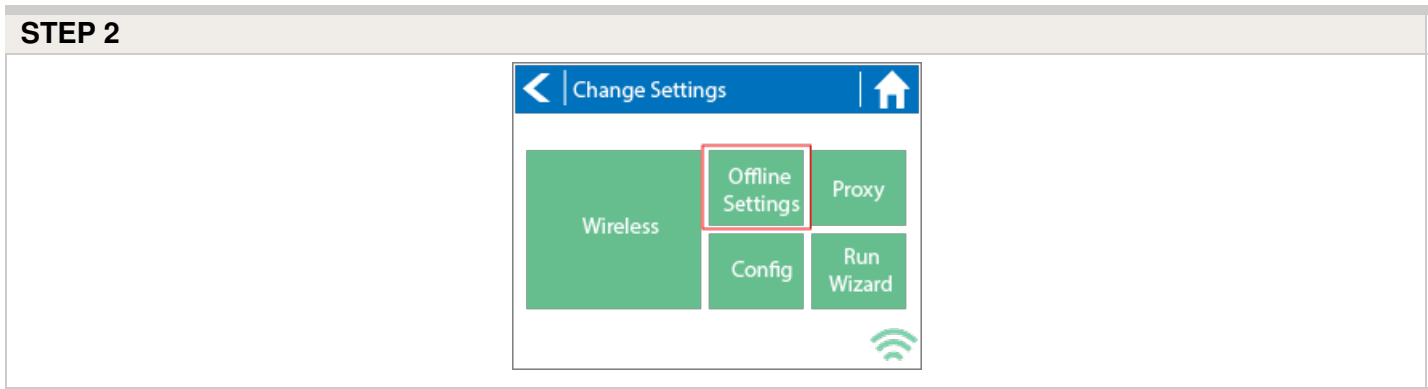
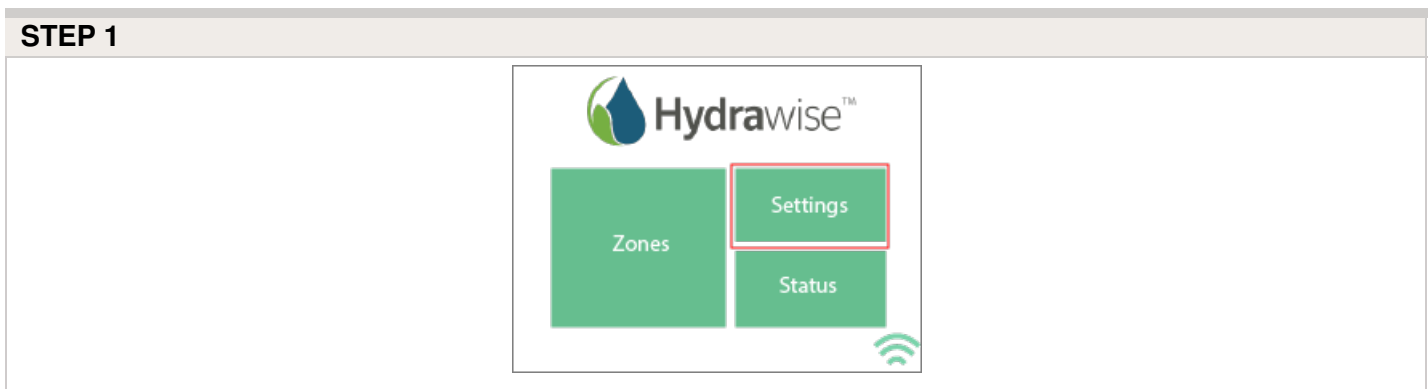

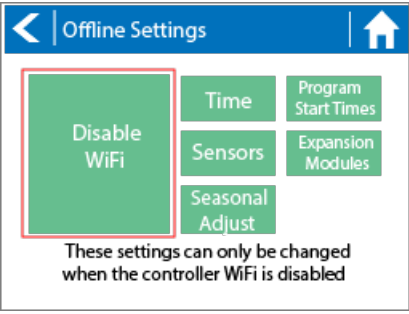

STEP 4

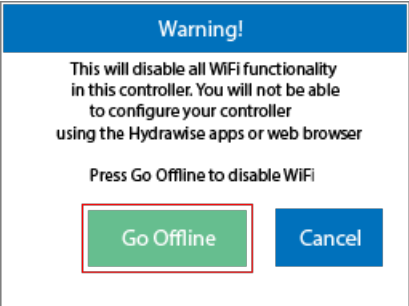

STEP 5

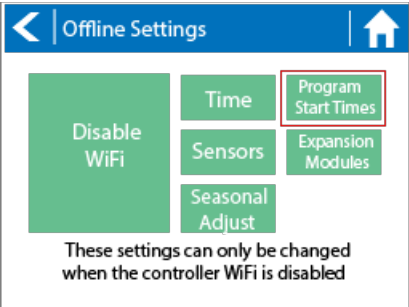

STEP 6

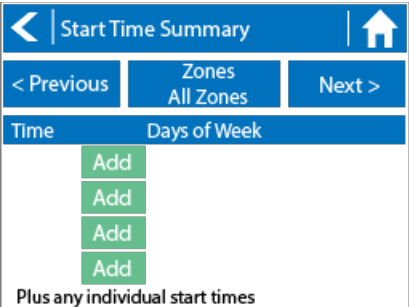

STEP 7

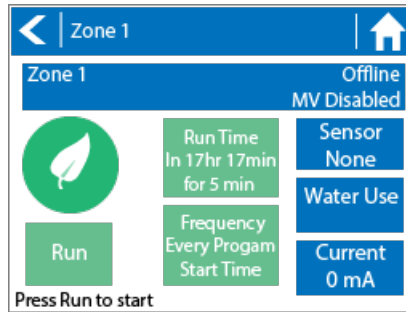

NOTE: To get your controller back in online mode, follow the above steps, enable Wi-Fi, reconnect to your SSID (Wi-Fi connection), and let the controller synchronize with your online Hydrowise account.

Offline Mode - Run the Setup Wizard

Please follow the steps below to run the setup wizard in offline mode. Refer to [Setting Controller to Offline Mode](#) ^[26] or [How to Factory Reset Controller](#) ^[27] before running the wizard.

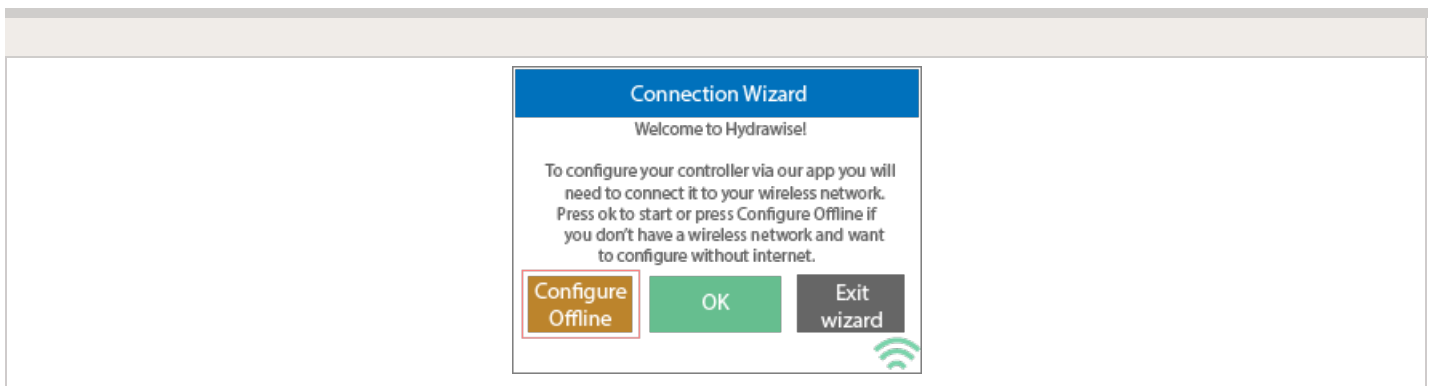

1. From the **Connection Wizard** screen, tap on **Configure Offline**. If you select **OK**, you will proceed to the online setup wizard.

2. Tap **OK** to move on to the next step.
3. Enter in today's date if it hasn't already been set or if it is incorrect.
4. Enter today's time if it hasn't already been set or if it is incorrect.
5. From this screen, tap **OK**.
6. Please assign your **Master Valve** if you're running one as advised on the previous screen. Otherwise, keep **Not Assigned** selected and tap **Confirm**.
7. Tap **OK**.
8. You can now enter (in minutes) the run length you want for your **default zone run time**. Then tap **OK**.
9. Tap **OK** to proceed to the next screen.
10. Next, set how often each zone will run. As advised on the previous screen, you can set individual frequencies for each zone.
11. Tap on **OK** to proceed.
12. From this screen, you can manually configure each zone according to your desired schedule. Simply tap on **Add** to add a program start time and follow the steps below. You can toggle between zones by tapping on **Next/Previous** or you can leave the start time to **APPLY to ALL ZONES**.

Note: Each zone can have up to four program start times and an additional four start times under the All Zones section as shown below. Applying the start time to ALL ZONES will run through all zones with a single start time.

1. Tap **ADD** in the start times menu.
2. Select the green box upper in left to enter **PROGRAM START TIME (24 hr format)**
3. Tap the **DAYS** to be selected **after** finished with start time entry.
4. Tap **CONFIRM** to save the start time entry.
5. Add a second start time for all zones or single zone if desired.
6. Tap the **HOME** icon (upper right) to allow station run times setup.

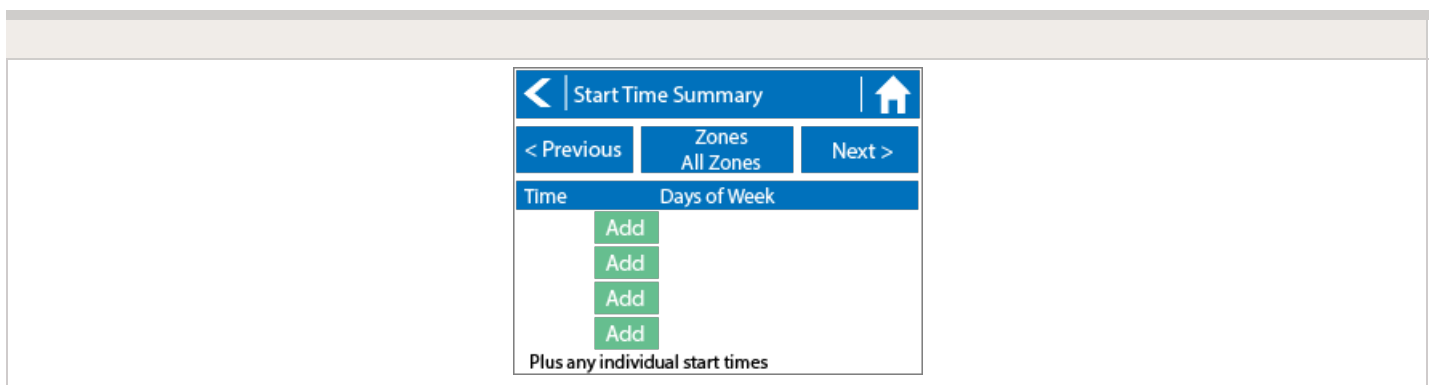

From the home screen, you can manually configure each zone run time. Simply tap on **ZONES** to add a zone run time and follow the steps below. You can toggle between zones by tapping on **each zone number**.

Note: The default run time and default watering frequency are applied to all zones during the setup wizard. Setting individual run times and frequencies is done by going into each zone afterwards

1. Tap **ZONES** in the home menu.
2. Tap the first zone to edit, (**For Example: ZONE 1**).
3. Tap on **RUN TIME** in the center of the screen.
4. Enter **RUN TIME (minutes:seconds format)**, then press **OK** to save entry.
5. Repeat steps **1-4** for station run times.

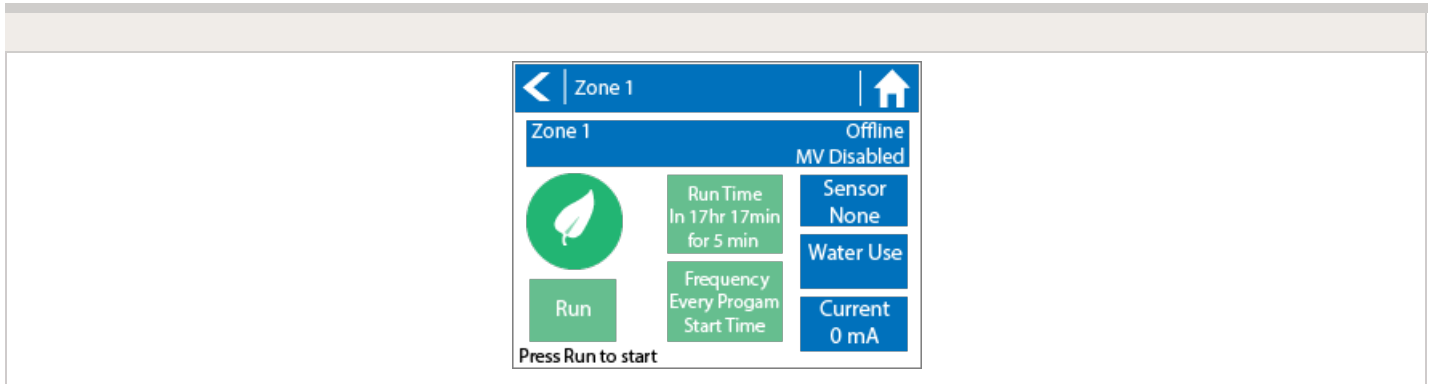

NOTE: To get your controller back in online mode, follow the above steps, enable Wi-Fi, reconnect to your SSID (Wi-Fi connection), and let the controller synchronize with your online Hydrowise account.

Offline Mode - Sensors

Please follow the steps below to add and configure your sensor or flow meter in **Offline Mode**. Please use the following link for [Installation Instructions](#) ^[28].

1. From the main menu, select **Settings**.
2. Next, select **Offline Settings**.
3. Select **Sensors**.
4. From this screen, you can now navigate between **Sensor 1** and **Sensor 2** by using the **Next** and **Previous** options. Just as you configure your sensors online, you can select the different options to make changes accordingly.

STEP 1



STEP 2

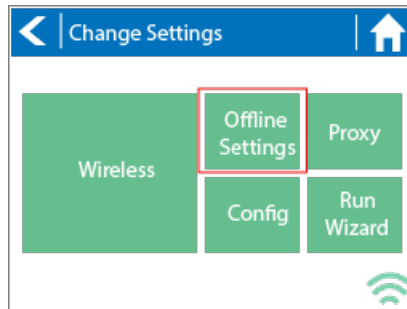

STEP 3

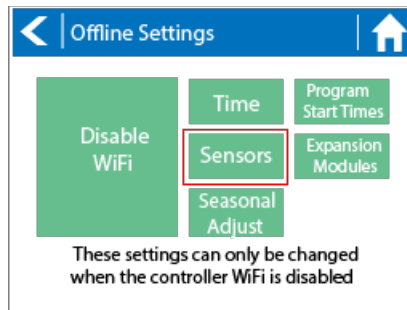

STEP 4

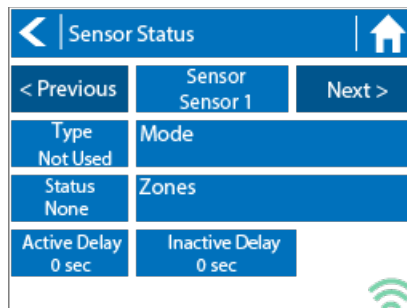

Sensor Status Options	
Type Options	Not Used, Level (Rain Sensor) or Flow Meter
Mode	Stop when open, Stop when closed, Start when open, or Start when closed.
Status	Open or Closed
Zones	Applies to all zones
Active Delay	Seconds
Inactive Delay	Seconds

Offline Mode - Turning Off Start Times

From the controller, you can manually turn it off by removing the start time when the controller is NOT connected to Wi-Fi using offline mode. Please follow the steps and screenshots listed below:

1. Select "**Settings**" in the home menu at the controller.
2. Select "**Offline Settings.**"
3. Select "**Program Start Times**" on the upper right side of the screen.
4. Select "**Modify**" which will allow you to edit you start times.
5. Finally, Select "**Delete**" button to no longer allow controller to run in offline mode.

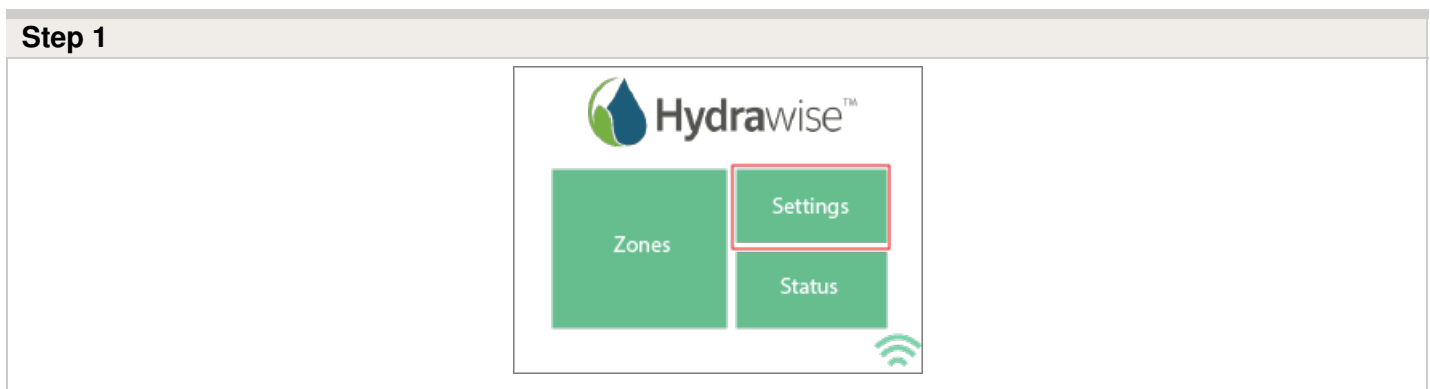

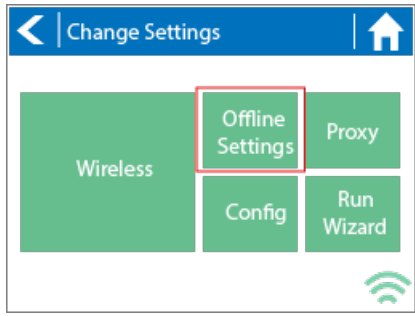

Step 3

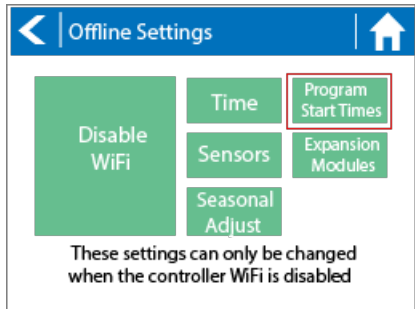

Step 4

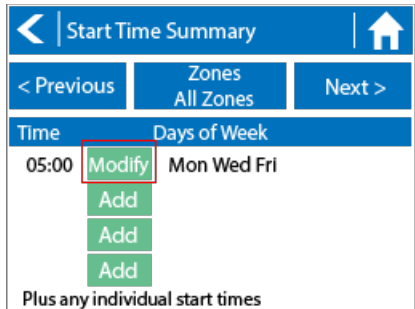

Step 5

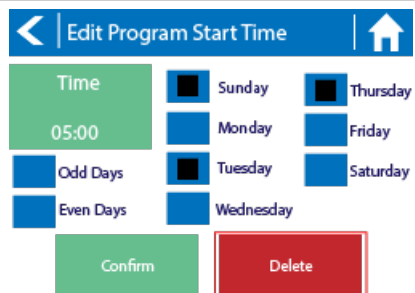

Offline Mode - Seasonal Adjust

Offline water adjustments allow the controller to automatically adjust the amount of watering on a month by month basis if the controller is in an Offline mode (ie. not connected to the internet). Steps below will cover both online and offline instructions on changing the seasonal adjust for when the controller enters offline mode.

Online: Offline Water Adjustment

1. Select the **three gears** on the upper right.
2. Scroll down to **configuration**.
3. Offline adjustments will be towards the bottom of the page. Sliders can be moved to adjust the offline watering from 0%-300%.

STEP 1-2

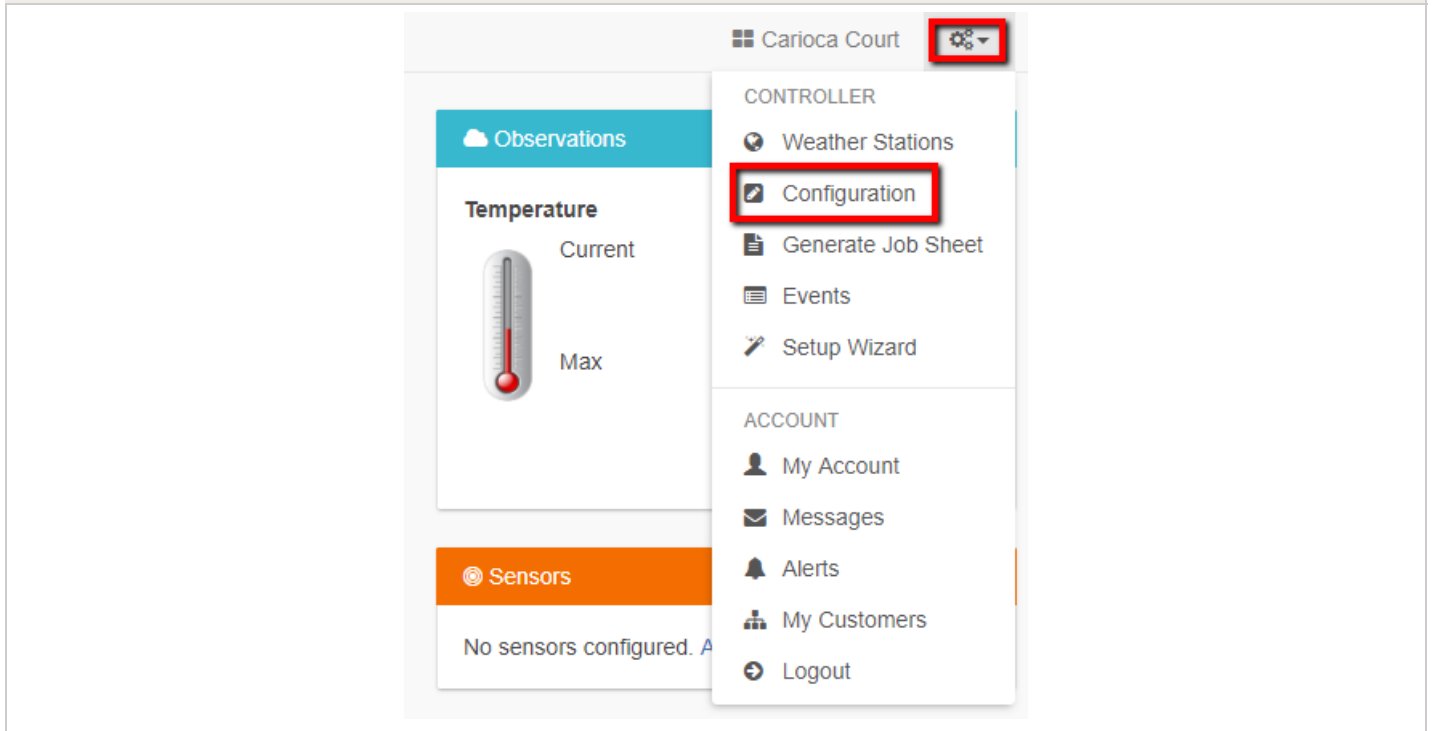

STEP 3

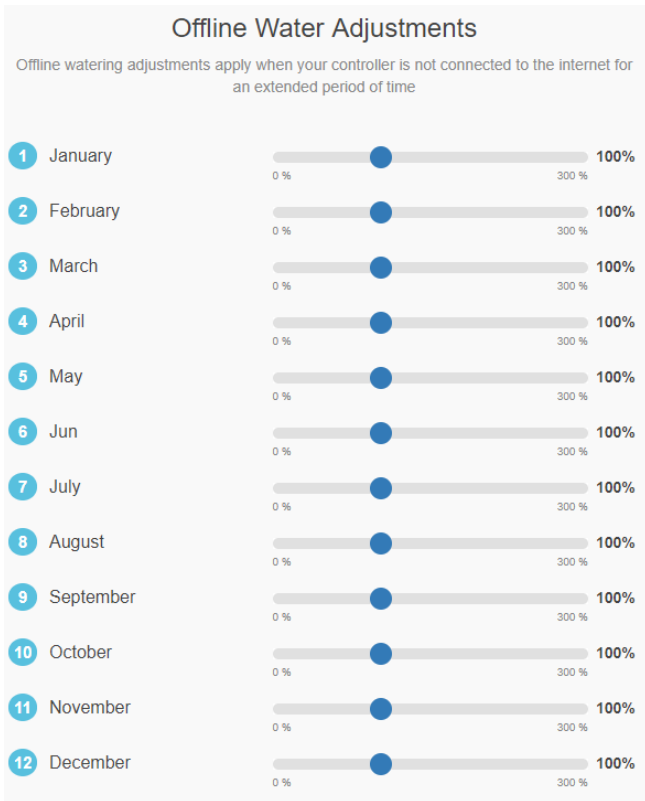

Offline: Offline Water Adjustment

1. Select settings.
2. Next, select offline settings.
3. Select seasonal adjust.
4. Select a month to adjust.
5. Adjust each month by a percentage then select OK.

CONTROLLER SCREENSHOTS:

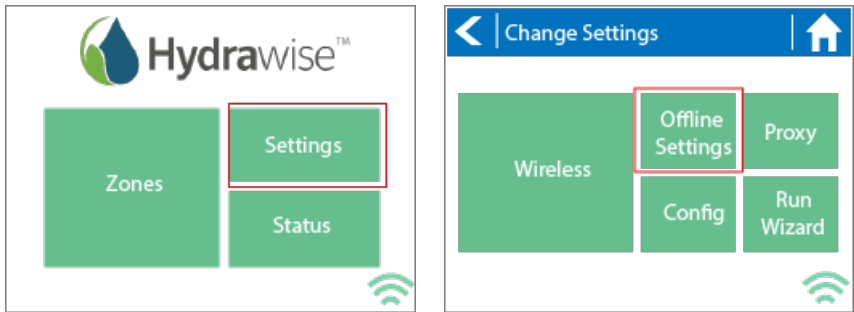

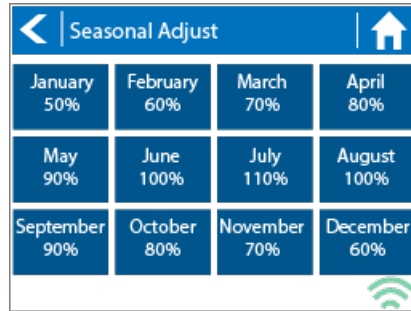
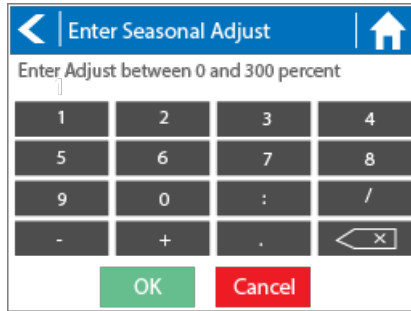
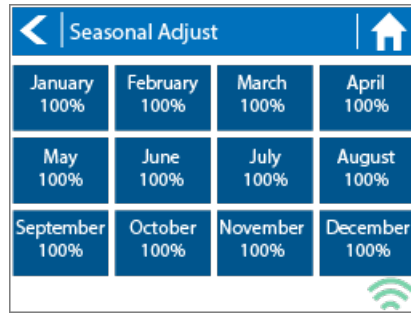
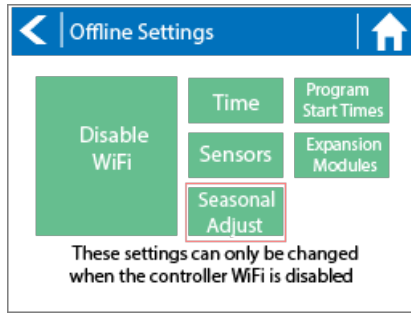

Account - API Information

Thank you for your interest! The Hydrawise API is coming soon...

Please register your interest with Anthony.Long@hunterindustries.com ^[29]

Thank You

Technical Support

Smart Voice Device - Amazon Alexa

In this guide, we will explain how to link your Amazon Alexa account with your Hydrawise account. Once you have linked your Alexa account to your Hydrawise account, you will be able to start, stop, or suspend zones using voice commands to your Alexa device. For example, you can say, "Alexa, ask Hydrawise to start Zone 1."

NOTE: Alexa supports only one controller per account. If you have multiple controllers linked to your account, Alexa does not know which controller you are referring to and will not be compatible. We now have Amazon Alexa approved for the following countries USA, Canada, Germany, and India.

Adding the Hydrawise skill to Alexa

To get started, you will need to make sure you have a Hydrawise account and have your controller configured. If not, please register for a free account [here](#). ^[30] Once you have your Hydrawise account ready, log in to your Alexa account (if you don't have one yet, you can register [here](#) ^[31]). The Alexa account and your Hydrawise account can have a different email address without an issue.

1. Go to the **Skills** section on your Alexa Dashboard.
2. Search for the "**Hydrawise skill**," and select it.

SKILLS

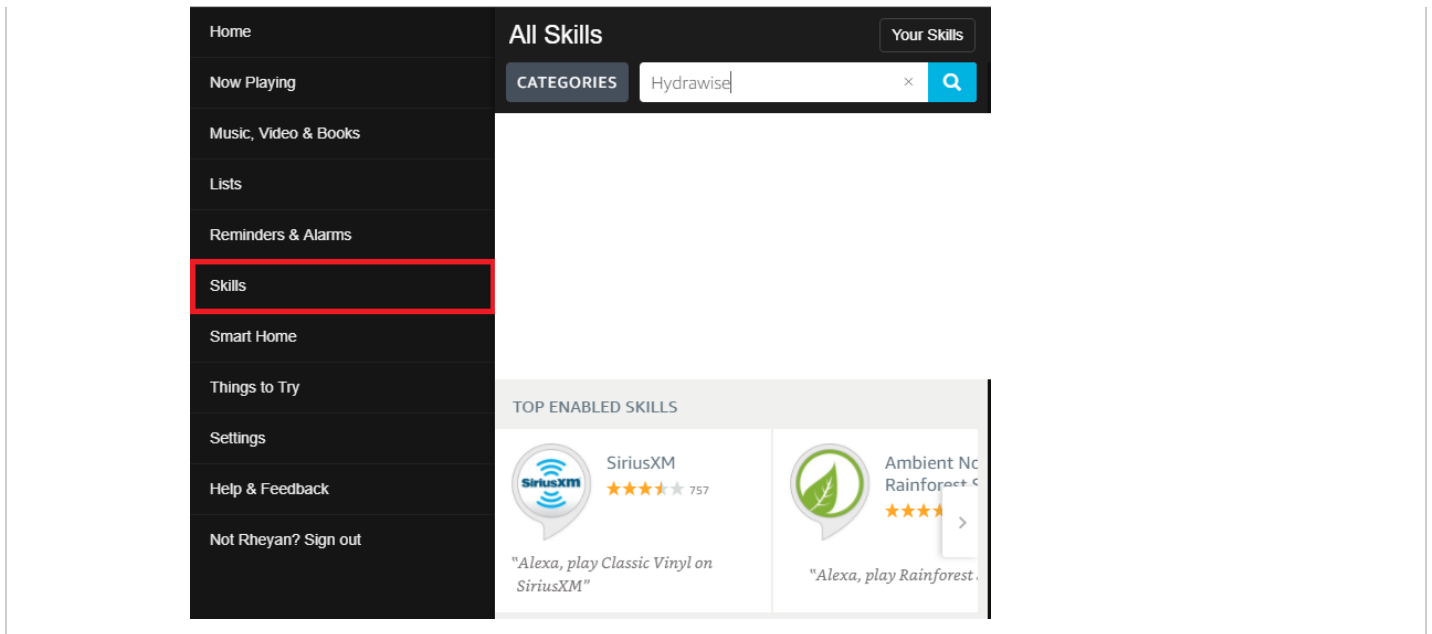

1. Click **ENABLE**.

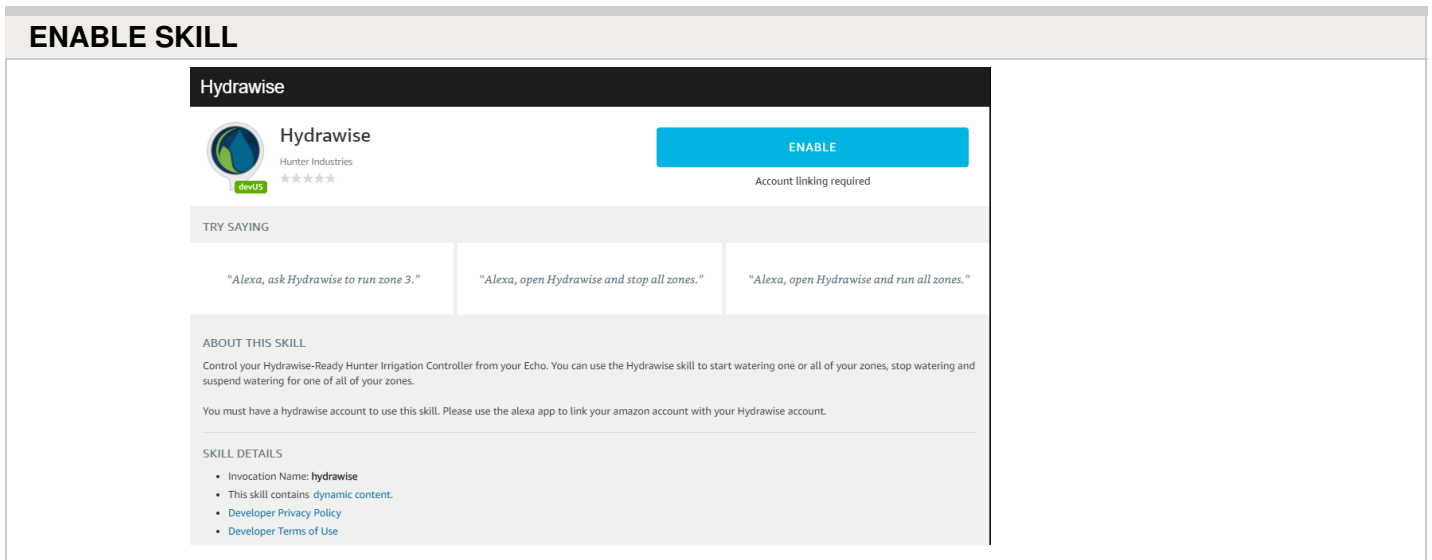

This will open a new window where you can log in to your Hydrawise account.

IMPORTANT: Please make sure you have pop-ups enabled for the Hydrawise log-in window. If pop-ups are blocked, you will not be able to log in and continue the linking process.

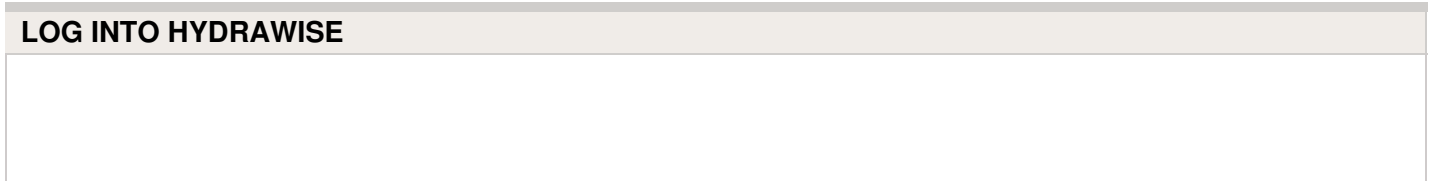

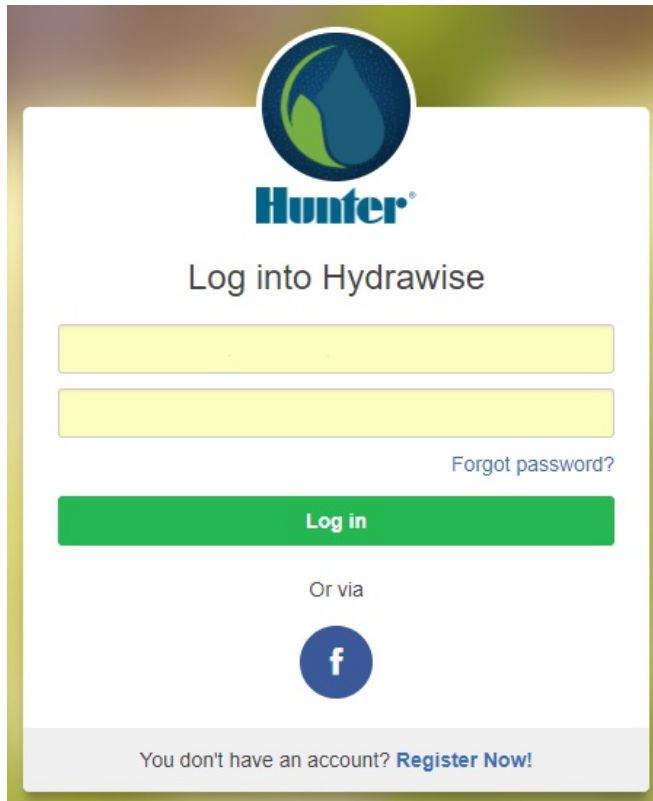

If you are already logged in, you will see the next dialogue box appear.

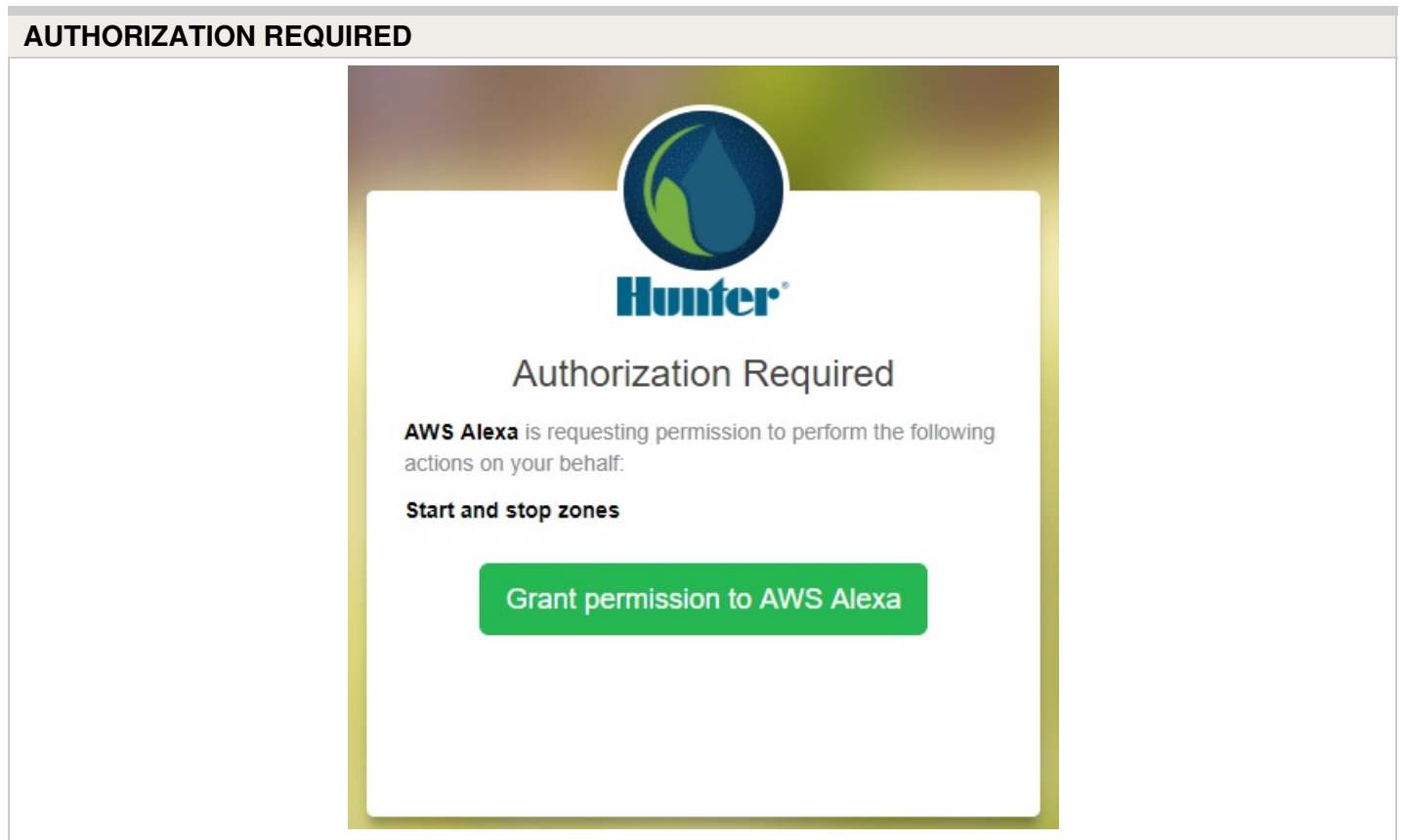

Click **Grant permission to AWS Alexa**.

You will then receive a confirmation that Hydrawise was successfully linked and you can close the window.

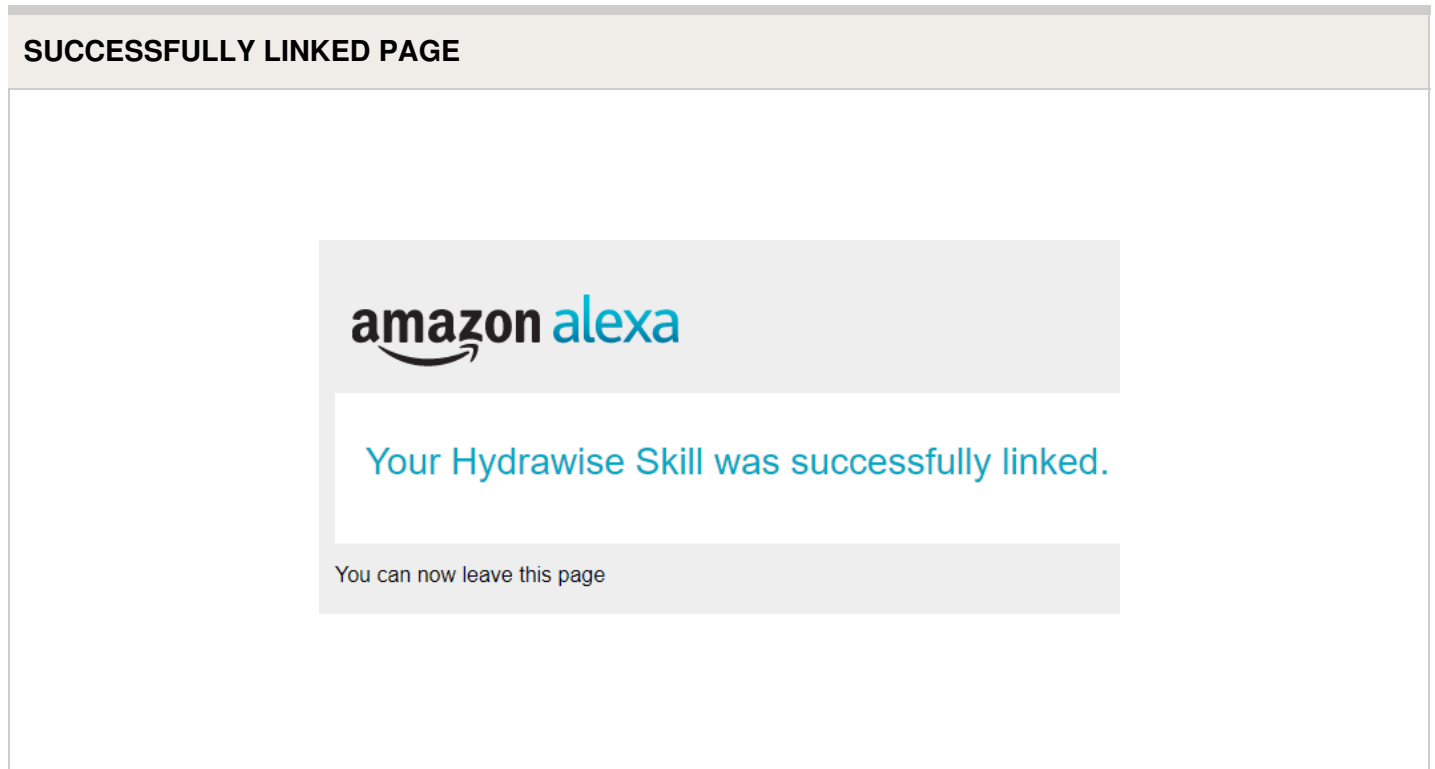

Using Alexa to control your Hydrawise

Zones can be started or stopped by referencing the zone number (do not use the zone name). For example, if your Zone 1 is called “Front Garden” and you want to start it, you can say, “*Alexa, ask Hydrawise to start Zone 1.*”

Alexa supports the following key phrases:

- Alexa, ask Hydrawise to start/run zone {number}.
 - This command will start a single zone for its default irrigation time.
 - e.g., *Alexa, ask Hydrawise to start Zone 5.*
- Alexa, ask Hydrawise to start/run zone {number} for {x} minutes.
 - This command will start a single zone for a specific time
 - e.g., *Alexa, ask Hydrawise to run Zone 1 for 10 minutes.*
- Alexa, ask Hydrawise to start/run expander {expander number} zone {number}.
 - This command will start a single zone on controllers with expansion modules
 - e.g., *Alexa, ask Hydrawise to start Expander 1, Zone 1.*
- Alexa, ask Hydrawise to start/run all zones.
 - This command will start all zones for their default irrigation time.
- Alexa, ask Hydrawise to stop/finish zone {number}.
 - This command will stop a single zone if it is currently running.
- Alexa, ask Hydrawise to stop/finish expander {expander number} zone {number}.

- This command will stop a single zone on an expansion module.
 - Alexa, ask Hydrowise to suspend zone {number} until {time/date}.
 - This command will suspend all zones for a period of time.
-

Home Automation - Control4

Hydrawise is now compatible with Control4 home automation software.

Control4 installers can now download drivers to allow the integration.

From the Control4 app, you can access the following features:

- View icons and zone information
- View proposed watering
- Manually start a zone
- View active (watering) stations

NOTE: More details on Control4 integration can be found using this link: [Control4 Details](#)

[32].

HPC - Upgrading Pro-C

Ensure you have a strong Wi-Fi signal. Wi-Fi connectivity can be tested on the HPC panel itself (signal strength is shown when you select a wireless network). If you have any issues connecting the controller to the router, please verify all Wi-Fi specifications [here](#) [1].

Remove Pro-C Face Panel

1. Remove ribbon cable with power off.
2. Press down on white hinge release button.
3. Remove face panel.

Install HPC-FP Face Panel

1. Press blue hinges together and attach new HPC panel.
2. Reconnect ribbon cable
3. Close and turn power on

STEPS



For information on complete setup in the application, please visit our "[How To Guide](#) ^[33]" section.

HCC - Valve Wiring

1. Route valve wires between control valve location and controller.
2. At valves, attach a common wire to either solenoid wire of all valves. The most commonly used color for the common wire is white. Attach a separate control wire to the remaining wire of each valve. All wire splice connections should be done using waterproof connectors.
3. Open hinged faceplate on the controller to access the terminal strip area.
4. Route valve wires through the conduit and attach conduit to the controller at the large conduit opening on the right side of the bottom of the cabinet. The conduit opening has a triple knockout to accommodate 1", 1¼", or 1½" (25, 32, or 40 mm) conduit. Each

section can be easily removed using a knife.

- Strip ½" (13 mm) of insulation from ends of all wires. Secure valve common wire to **C** (Common) terminal on any of the valve modules or power module. Then attach all individual valve control wires to appropriate station terminals.

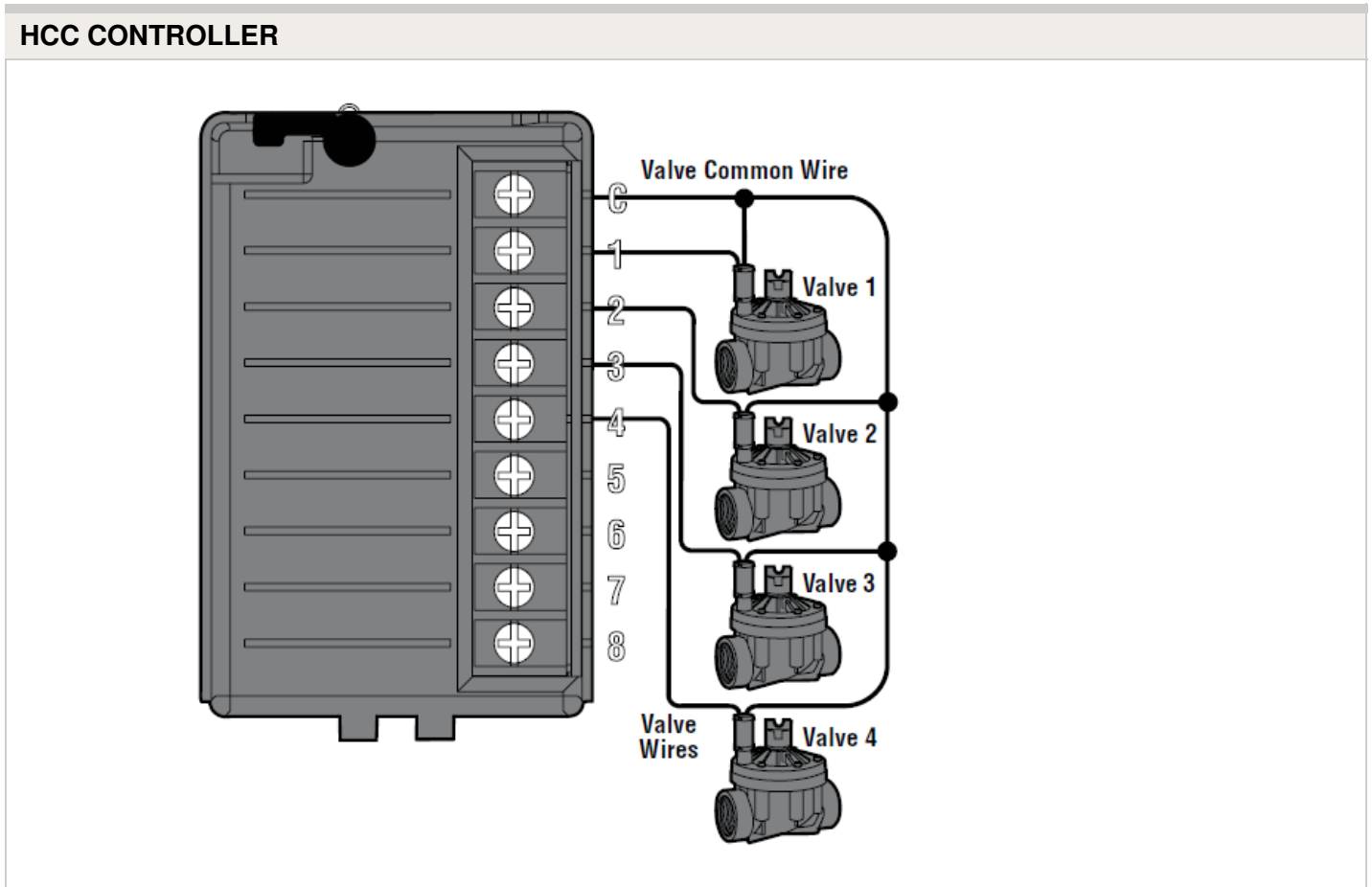

HCC - AC Wiring

Connecting the controller to primary AC power should be done by a licensed electrician following all local codes. Install in approved conduit and fittings. The controller can operate with either 120VAC or 230VAC power. Supply wires must be 14AWG/ 2 mm² or larger.

- Turn AC power "**off**" at the source, and verify that it is off.

2. Disconnect the "**facepack**" ribbon cable.
3. Remove the "**facepack.**"
4. Remove the "**cover**" from the junction box.
5. Strip about **0.5"** (13 mm) of insulation from the end of each AC power wire.
6. Route the wires through the "**conduit opening**" inside the junction box.
7. Connect AC wiring using supplied terminal block (or taped wire nuts where permissible).

2a.

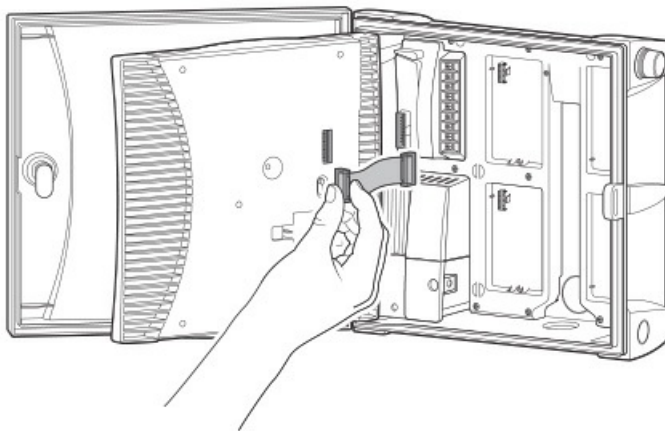

2b.

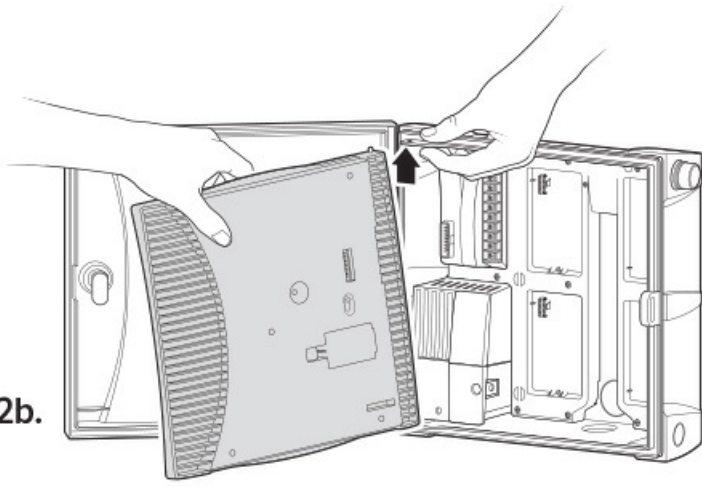

2c.

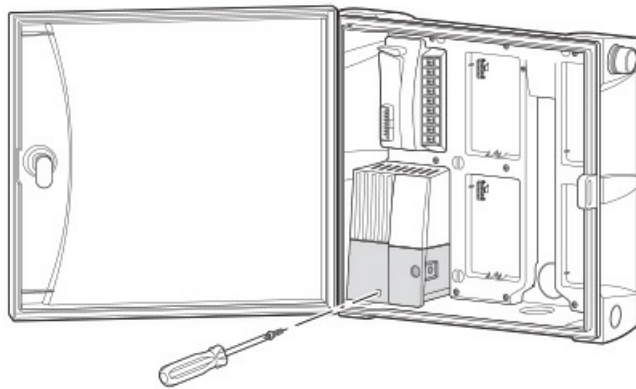

Wiring Block

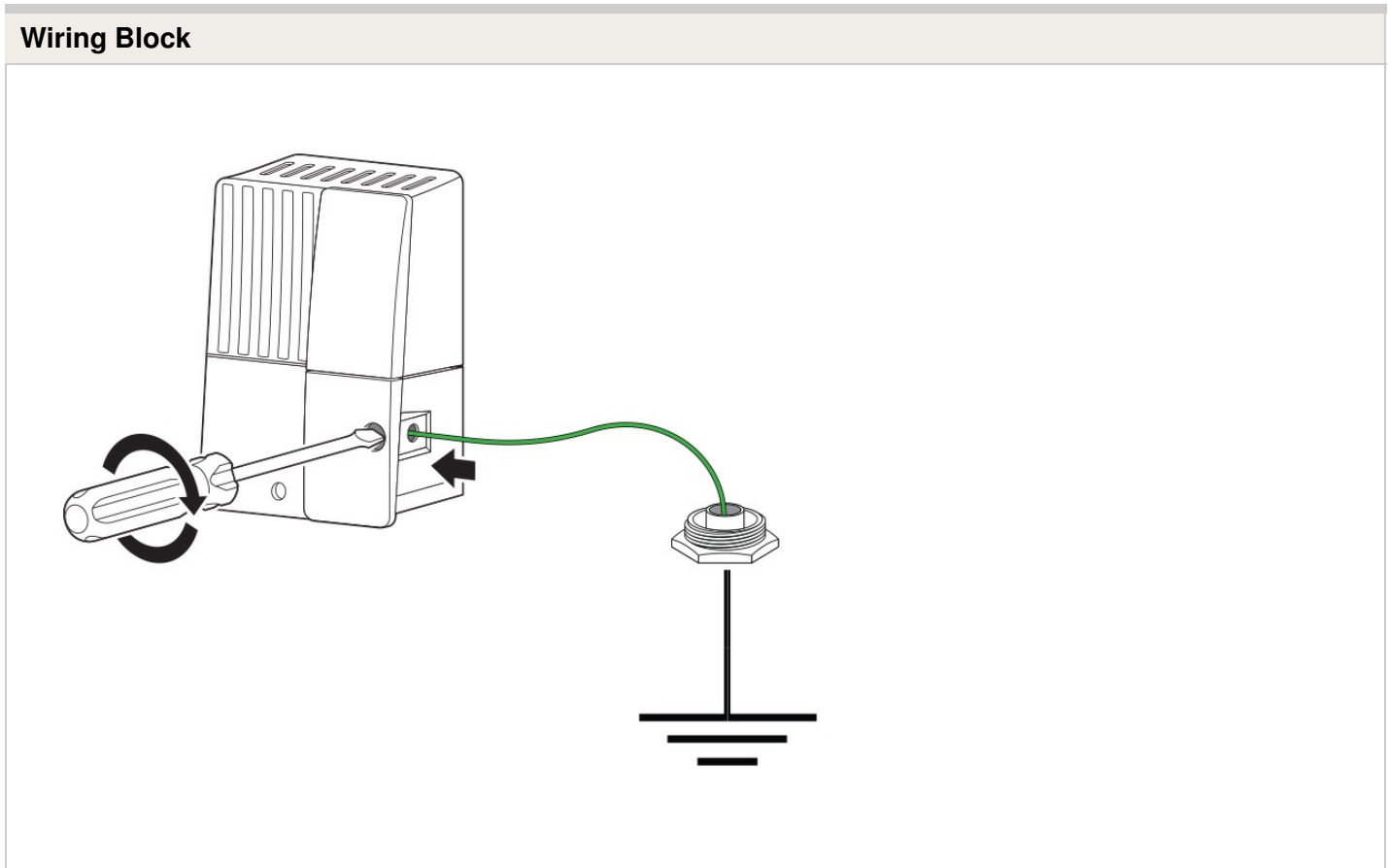
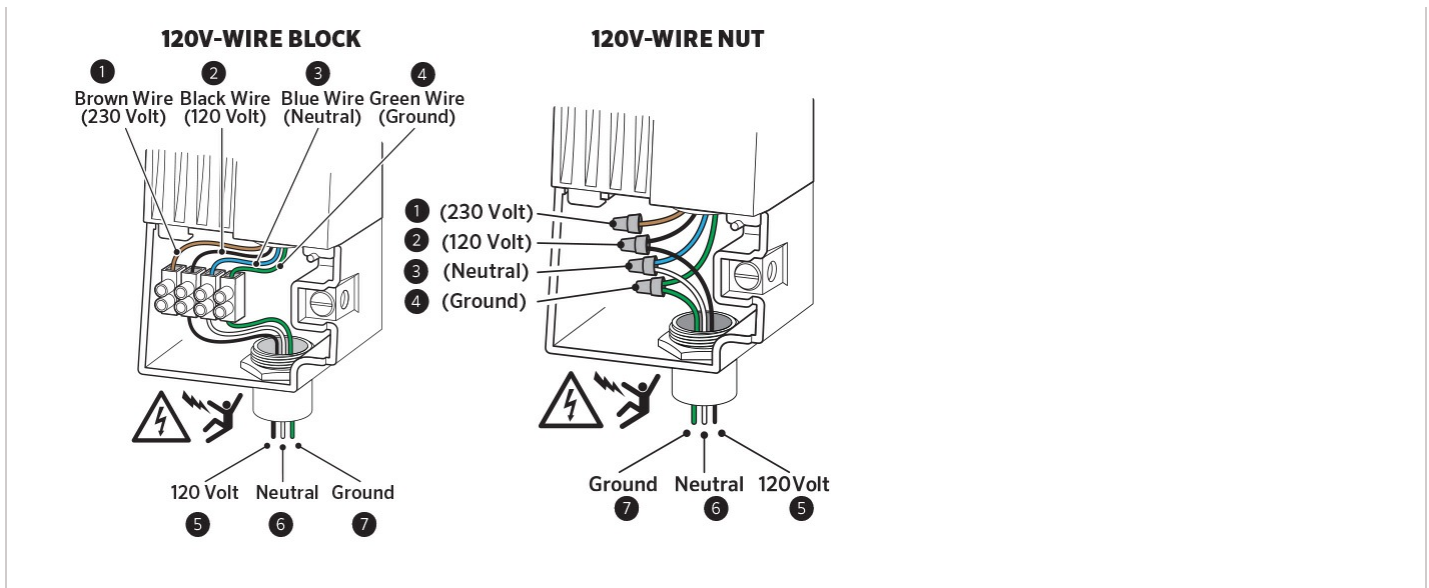

1. Insert copper wire from earth ground hardware, and tighten screw in front.
2. Minimum 10 AWG/5mm² wire to earth ground hardware.
3. Add copper-clad steel ground rods and/or plates sufficient to achieve 10Ω or less resistance at a minimum 8'/2.5 m away from controller.

HPC- WRCLIK and HC Flow Meter

In the event you will need to install a flow meter and a rain sensor on the **HPC** controller, please use the following instructions. The **HPC** controller utilizes a single SEN output so these steps are necessary to make this work. For correct field wiring of the flow meter, please reference the article [here](#). [34]

NOTE: The software will only recognize the flow meter for this type of installation. The Wireless Rain Clik will still shut down system after a rain event, but this will not reflect anywhere in the software. The reports will not show ANY data for the rain events.

IMPORTANT: You will see alerts for underflow from the flow meter since the system will continue to run even with the common circuit interrupted by the rain event. These alerts will have to be ignored for this type of application. For more details on alerts, please view this article [here](#). [35]

Please reference chart and illustration below for controller wiring details.

Illustration	Terminals	Wires
Figure 1.	AC 1/ AC 2	WRCLIK Yellow
Figure 2.	COMMON	WRCLIK White
Figure 3.	Valve Common	WRCLIK Blue
Figure 4.	Flow meter - Blue/White	METER Blue/White

Right Click to View Larger image

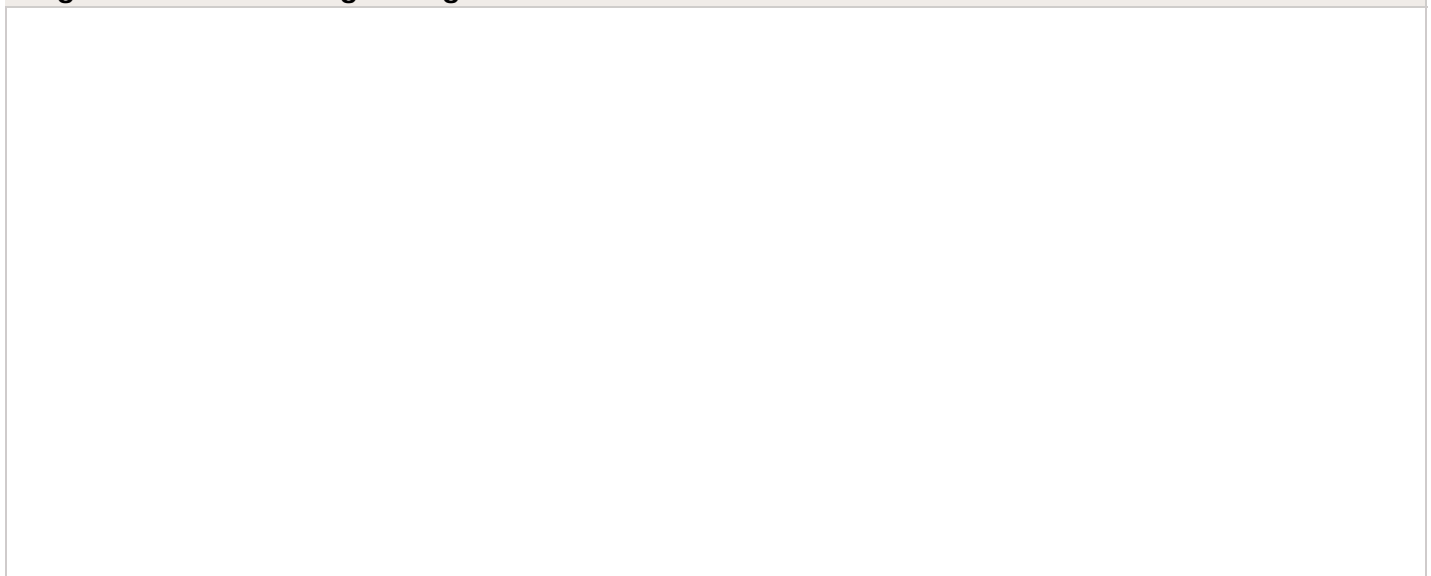

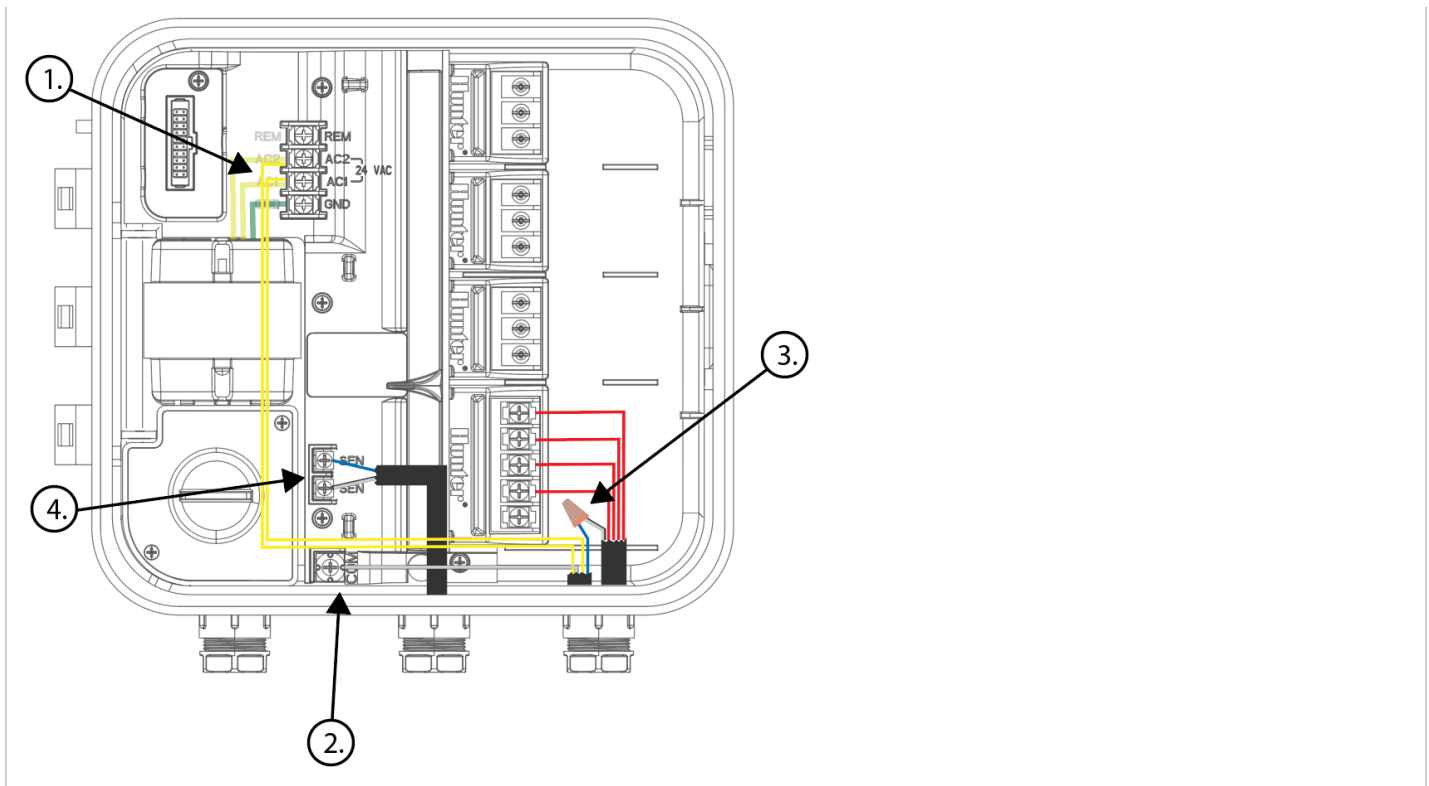

Flow Meter - Configuration

Assigning the Meter

Please view the steps and screenshots to access this feature:

1. Click on "**Sensors**" from the home dashboard.
2. Add "**Sensor.**"
3. Choose a **name**, **sensor type**, and **controller input** (flow related only).
4. Choose which **zones** should be linked to the sensor.
5. Click **ok** when finished.

Step 1

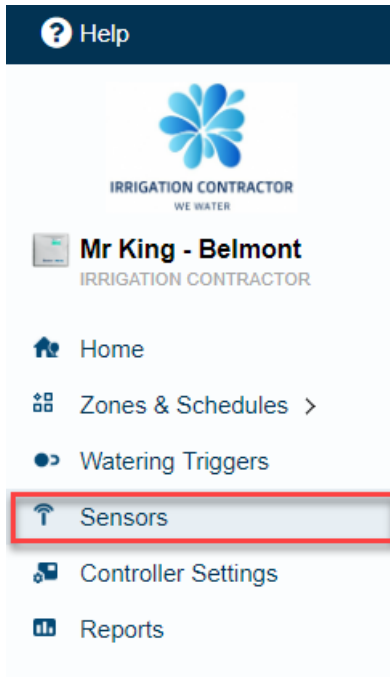

Step 2

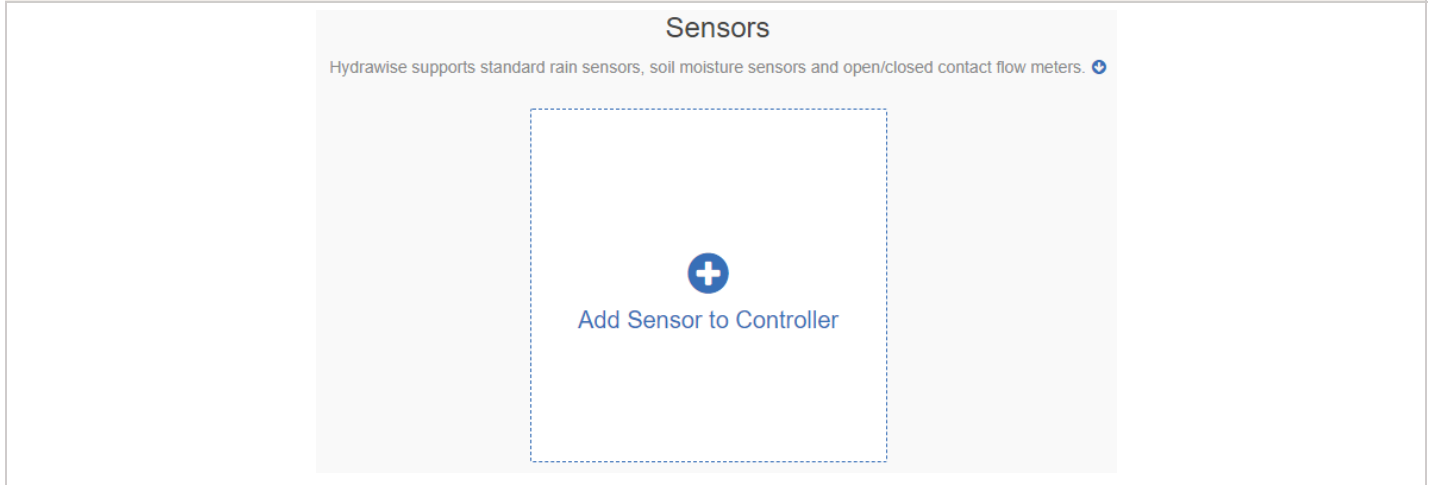

Step 3

Add Sensor ✕

Sensor details ▶ **Set zones**

Sensor Name
Assign a descriptive name for this sensor

Flow Meter

Type of Sensor
Choose the type of sensor you have installed. You can also create a custom sensor type if you have something non standard.

¼ inch NPT Flow Meter

Create New Sensor Type...

Controller Input
Choose the input on the controller that this sensor is wired to

SEN-1

Cancel < Prev Next > ✓ OK

Step 4

Add Sensor ✕

Sensor details ▶ **Set zones**

Select Zones
Select the zones which will use this sensor

Available zones

- Carioca Court
- Back Grass
- Back Drip
- Diamond Street Controller**
- Front Grass
- Front Flowers
- Back Drip

Selected zones

- Carioca Court
- Front Grass
- Street Drip
- Front Drip

Cancel < Prev Next > ✓ OK

Flow Meter - Quick Start Guide

Please click on the link below to download the flow meter connection guide.

[Connecting Your Hydrawise Flow Meter](#) ^[36]

Flow Meter - Installation Tips

Flow meters are supplied with [detailed installation instructions](#) ^[28].

The flow meter wires need to be cabled back to the controller and connected to the **Sensor** inputs on the controller. See chart below for wiring standard Hydrawise flow meters (Sizes include 3/4", 1", 1.5", 2")

FLOW METER WIRE	SCREW TERMINAL	CONTROLLER
BLUE	SEN 1, 2	HC
BLUE	SEN 1, 2	PRO-HC
BLUE	SEN	HPC-FP
WHITE	COM	HC
WHITE	SEN COM	PRO-HC
WHITE	SEN	HPC-FP
RED	Not Used, Cap off	N/A

The tips below include all the necessary key points of the install to avoid any false alerts or readings.

Installation Steps	Description
	Flow meters are designed to be installed horizontally only , with the dial facing up. Not vertically. Analog dial for manual readings

Flow Meter Body	in U.S. are shown in US gallons (Int. customers the dial reads in Cubic Meters). Units can be changed in App to gallons or liters.															
Adapter	Brass unions included to fit your irrigation system.															
Entry Location	<p>Install between the master valve and zone valves. Meter should be installed 10 times pipe diameter before and 5 times after with straight pipe and no fittings. See example:</p> <table border="1"> <thead> <tr> <th>Pipe</th> <th>10x-Before</th> <th>5x-After</th> </tr> </thead> <tbody> <tr> <td>3/4"</td> <td>7.5"</td> <td>3.75"</td> </tr> <tr> <td>1"</td> <td>10"</td> <td>5"</td> </tr> <tr> <td>1.5"</td> <td>15"</td> <td>7.5"</td> </tr> <tr> <td>2"</td> <td>20"</td> <td>10"</td> </tr> </tbody> </table>	Pipe	10x-Before	5x-After	3/4"	7.5"	3.75"	1"	10"	5"	1.5"	15"	7.5"	2"	20"	10"
Pipe	10x-Before	5x-After														
3/4"	7.5"	3.75"														
1"	10"	5"														
1.5"	15"	7.5"														
2"	20"	10"														
Cable used (shielded cable only)	<p>18 gauge - 1000 foot max Length. Shielded direct burial cable must be used. Cable should consist of two dedicated wires and must not be in the same conduit, cable bundle or trench as the solenoid wires. DO NOT share common wire. Shielded cable is commonly available, here are some manufacturers (Paige ^[37] & Regency ^[38]) For additional information on avoiding electrical interference, see below:</p>															
Flow meter body	Arrow indicates direction of flow.															
Wire Connection	Blue/White wire only, red not used . See sensor configuration ^[39] for more info based on model controller.															
Log in to your account	Enter your login ^[8] information.															
Create your flow sensor	App will show options for all HC meters.															
Creating Alerts	See link here ^[40]															
Reading Meter	See link here ^[41]															
Testing Meter	See link here ^[42]															

Avoid Electrical Interference

- Always use shielded cable, between the controller and the HC Flow Meter.
- At the controller end, using the shield (foil wrap) and the bare wire connect them to the controller GND terminal (not required for HC controllers).
- Do not connect the other end of the Shield or the bare wire to the Earth or a grounding stake
- Use Waterproof wire connectors at the flow meter, such as [3M 316IR](#) [43] or [3M DBY](#) [44]
- Shielded cable is commonly available, here are some manufacturers. [Paige](#) [37] & [Regency](#) [38]

In the event you continue to receive bad readings or false alerts, please contact us support@hydrawise.com [19]

Flow Meter - Specifications

HC FLOW METER SPECIFICATIONS



	HC-075-FLOW (¾")	HC-100-FLOW (1")	HC-150-FLOW (1½")	HC-200-FLOW (2")
	¾" NPT body,	1" NPT body, male	1½" NPT body,	2" NPT body, male

Inlet/outlet connection size	male thread with 1" NPT male adapter	thread with 1.5" NPT male adapter	male thread with 2" NPT male adapter	thread with 3" NPT male adapter
Meter internal diameter	3/4"	1"	1.5"	2"
Minimum flow (GPM)	0.22	0.3	0.88	1.98
Maximum recommended flow (GPM)	15	30	66	105
Maximum flow rate (GPM)	21	34	88	132
Dial reading (US gal)	1 pulse per 0.1 U.S. gal	1 pulse per 1 U.S. gal	1 pulse per 1 U.S. gal	1 pulse per 1 U.S. gal
Maximum working pressure (PSI)	230	230	230	230

Flow Meter - Reading Meter

The Hydrowise flow meters come in a US Gallon reading for domestic and metric reading called M³ (Meters Cubed 1000 Liters) for international. Conversion rate for metric meters is 3.78 Liters to 1 US Gallon if required.

See example of meter reading below in US gallons:

Fig. 1	X100	8100 Gallons
Fig. 2	X10	814X.XX Gallons
Fig. 3	X1	8142.XX Gallons
Fig. 4	X0.1	8142.4X Gallons
Fig. 5	X0.01	8142.46 Gallons Total
Fig. 6	Size meter	1"
Fig. 7	Flow Indicator	Wheel spins when water is flowing.

We have a flow that has gone through the meter of 8,142.46 gallons.

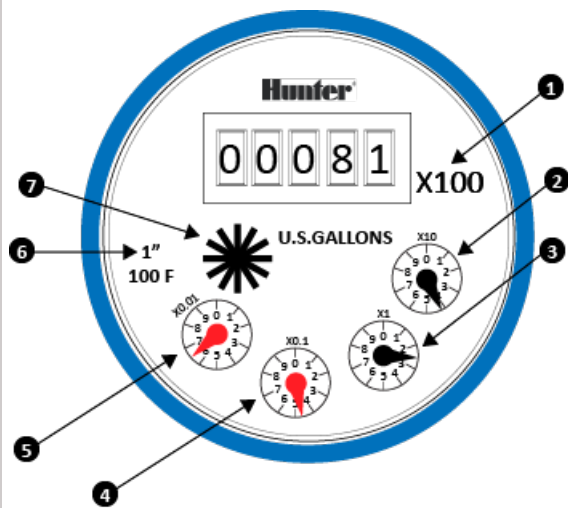

Flow Meter - Testing Meter

If your flow meter is working but is not recording data in your **Dashboard** or events, follow the steps here:

1. If you can access the wires at the flow-meter end, strip the two wires back (if you're using quick disconnects, you can use a paper clip or wire to make contact) and touch them together. Do this 10 times, as each contact will record a pulse.
2. Access your app and see if flow data was registered.
 - If yes, your wiring and system are set up correctly. Reconnect to the flow meter and run a large flow (lots of sprinklers) zone. Did you get a flow on your app? If yes, all is OK. If no, contact support@hydrawise.com ^[45].

- If no, go back to the controller and use another piece of wire to connect one end to either sensor 1 or sensor 2 (the port the flow meter is normally connected to). Then tap the other end against the sensor common (in the blue section). Do this 10 times.

3. Go to the app and see if it registered flow data.

- If yes, there is a problem with the wire running to the flow meter.
- If no, contact support@hydrawise.com ^[45].

4. To test the sensor inputs on the controller, you can use the same method with a paper clip or wire to make contact between sensor 1/sensor 2 and the sensor common. Do this 10 times and then check for flow data in your Dashboard.

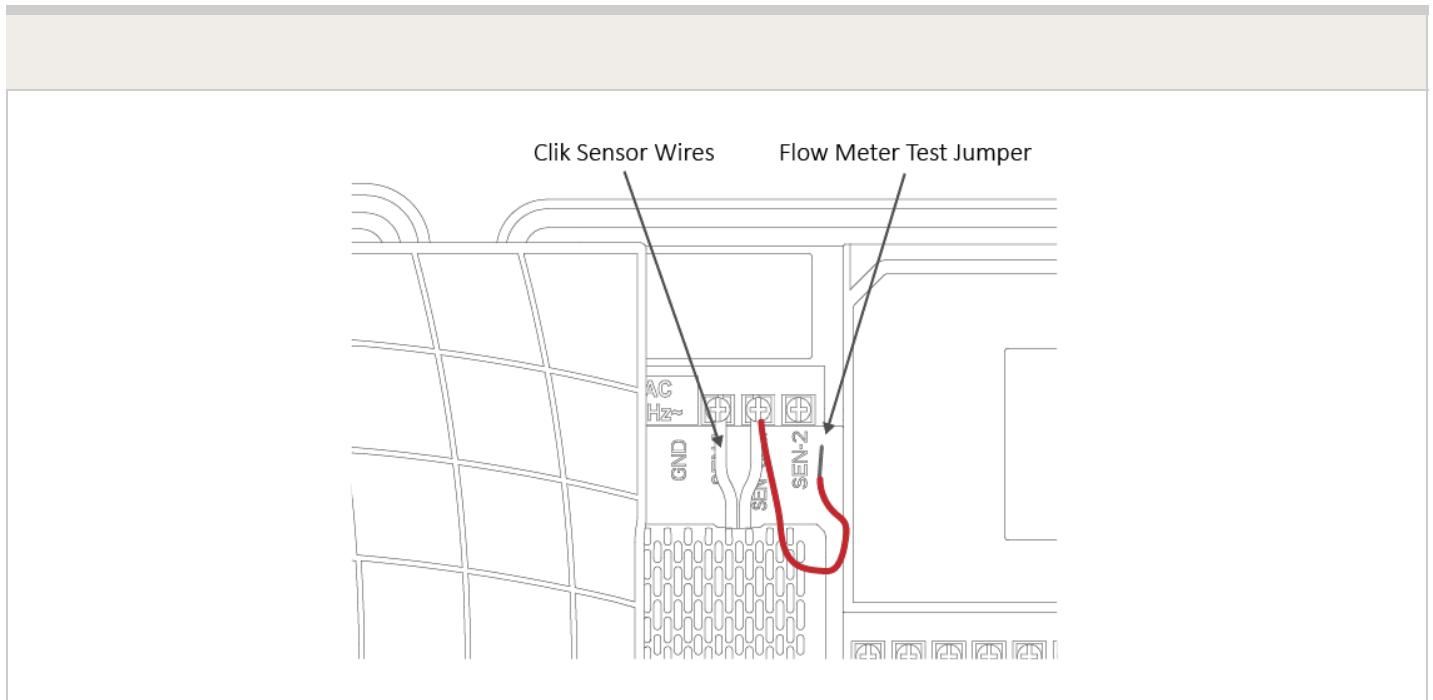

IMPORTANT: Our controller is not polarity sensitive. There is no risk of electric shock when performing these tests. However, if you feel uncomfortable, please contact a qualified technician or irrigation specialist for further assistance.

NOTE: If it works at the controller end but not the flow-meter end, there is a wiring fault.

If it doesn't work at the controller end, contact support@hydrawise.com ^[45].

If it works at both ends, but still does not register flow on the app, contact support@hydrawise.com ^[45].

Flow Meter - Custom Flow Sensor Configuration

To add a custom flow sensor, go to [Sensors](#) ^[46] from your web browser or smartphone application.

1. Click **Add Custom Sensor Type**

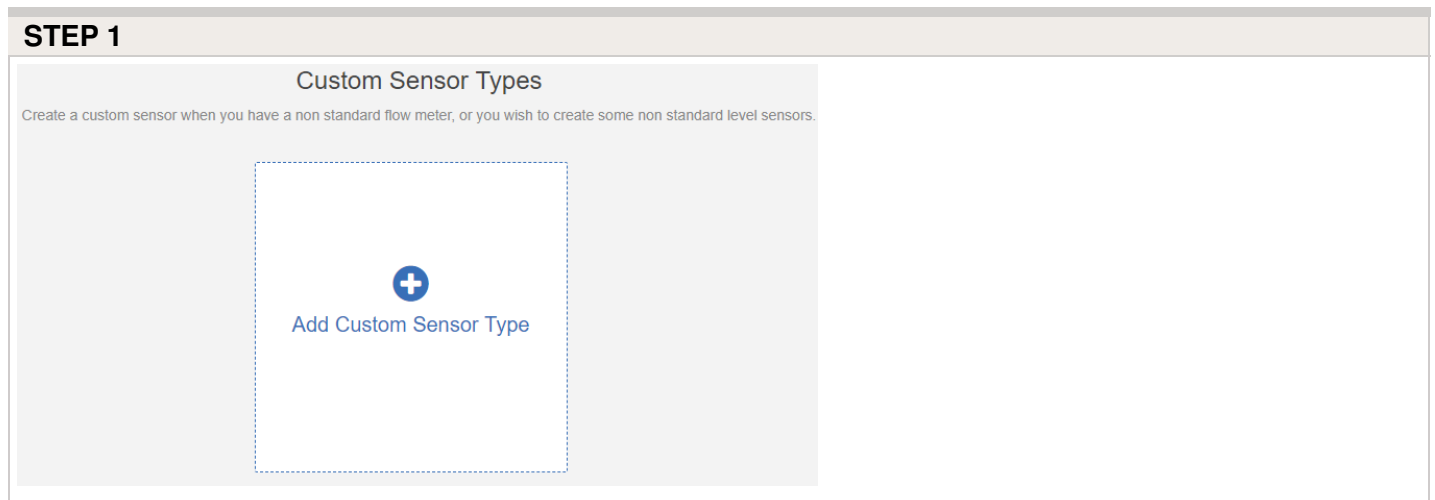

A dialogue box will appear for you to enter your custom flow meter details. Make sure you enter the calibration details for your custom pulse-based flow meter. Please refer to the manufacturer specifications to find out the calibration. Otherwise, you will not get accurate readings to display on your flow data.

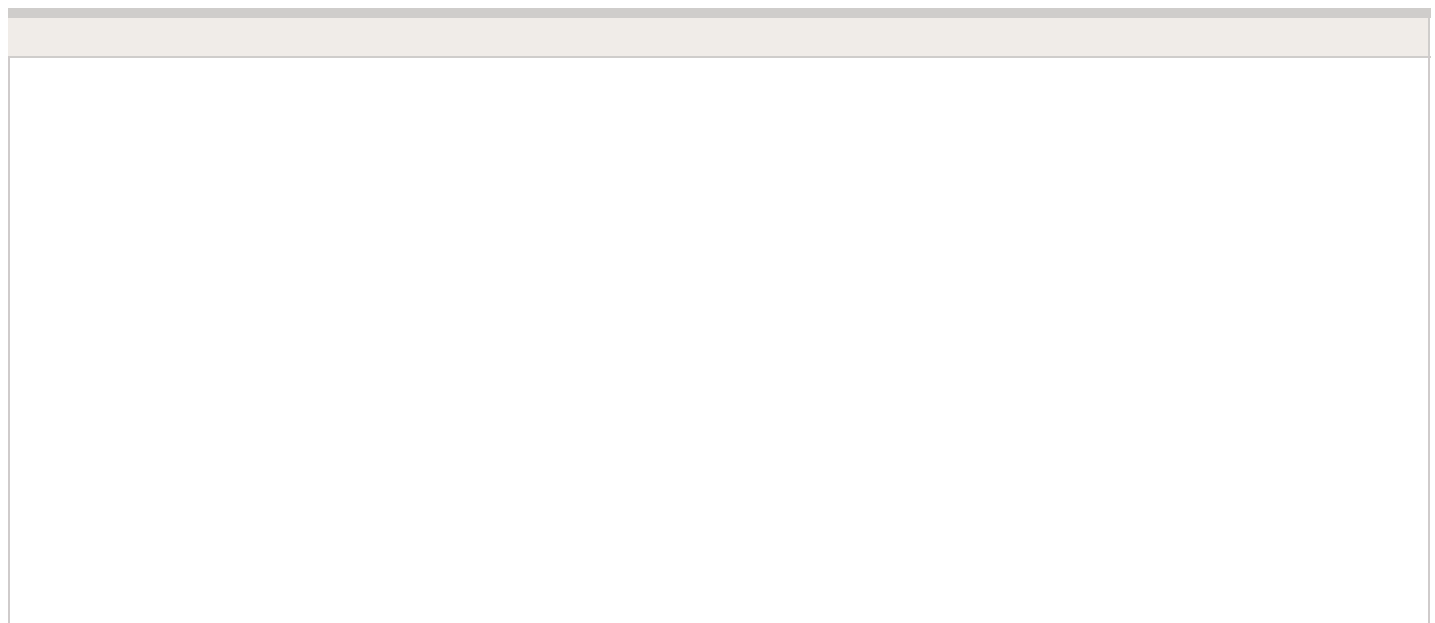

Edit Custom Sensor Type ✕

Sensor Type Name
Assign a descriptive name for this sensor definition

Type of Sensor
Flow Meter

Number of litres per pulse
0 litres per pulse

Flow Meter Action
Record water usage

Choose what actions this flow meter can cause

Cancel

NOTE: For our system to detect the correct flow data and reflect it on your **Dashboard** reports, any third-party flow meter used must be a true pulse flow meter or have a reed switch. We aim for a minimum of 10 pulses per min and a maximum of 120 pulses per min. That means if the flow rate was 10 gal per min, 1 pulse per gallon needs to be set.

When using a third-party flow meter, please ensure it meets the specs above and is calibrated correctly. Otherwise, data will not reflect accurately in reports. Also, note that the wiring is not polarity sensitive. As long as you have one wire in a **Sensor Port** and a **Sensor Common**, the device will work correctly. For flow meters that use three wires and meet the specs above, configure the wiring until you find the two correct wires to use.

Flow Meter - Winterization

We recommend that a qualified licensed contractor perform this type of winterization method. The blowout method utilizes an air compressor with a cubic foot per minute (CFM) rating of 80-100 for any mainline of 2" or less. The compressor is attached to the mainline via a quick coupler, hose bib, or other type connection, which is located beyond the backflow device. Compressed air should not be blown through any backflow or flow meter device. For additional winterization procedures, we highly recommend contacting the local

dealer for the most common local practices. In the event you need to blow upstream from where the flow meter is located, we recommend bypassing the meter by temporarily installing a SCH 80 or galvanized nipple. See the size chart below:

Model	Description	Male-Thread NPT	Nipple Length
HC-075-FLOW	¾" NPT body, male thread with 1" NPT male adapter	1" NPT	5"
HC-100-FLOW	1" NPT body, male thread with 1.5" NPT male adapter	1 ¼"NPT	5"
HC-150-FLOW	1½" NPT body, male thread with 2" NPT male adapter	2"NPT	11 ¾"
HC-200-FLOW	2" NPT body, male thread with 3" NPT male adapter	2 ½"BSP	11 ¾"

Find a Hunter Distributor closest to you using our interactive lookup - [Get Hunter](#) ^[47]

For step-by-step instructions on installing the nipple to bypass the flow sensor, **CLICK** on this link: [Flow Meter Winterization Bypass](#) ^[48]

Sensors and Flow Meter - Configuration

Hydrawise supports two types of sensors:

1. Flow sensors that measure water usage for an irrigation zone (or zones).
2. Rain sensors, wind sensors, and moisture sensors (sometimes called on/off sensors) that allow you to suspend watering cycles for a zone (or zones).

Flow Meters

Flow meters measure the amount of water going onto each zone. This is really useful for understanding water usage and monitoring issues such as broken pipes.

Hydrawise reporting allows you to see how much water is used for each zone and how much water is used across your system.

With a flow meter, you can also create alerts for flow issues, which will keep you up to date on what's happening (particularly important for unattended homes). See [Creating Alerts](#) ^[49] for more information.

Flow Meters	
US Hunter HC Flow Meters	3/4 inch NPT Flow Meter
US Hunter HC Flow Meters	1, 1/5, or 2 inch NPT Flow Meter
Metric Hunter HC Flow Meters	20mm BSP Flow Meter
Metric Hunter HC Flow Meters	25, 40, or 50mm BSP Flow Meter
Discontinued Sensors	Flow Meter with 3/4 inch coupling
Discontinued Sensors	Flow Meter with 1 inch coupling

Rain/Moisture Sensors

Hydrawise also supports standard open/closed contact rain sensors and soil moisture sensors. In fact, you can use any generic type of sensor that has an open/close contact.

These sensors use two wires and are usually labeled as normally open (sometimes called NO) or normally closed (sometimes called NC).

A rain or moisture sensor is usually used to stop irrigation. However, you can also create your own custom sensor types to start irrigation or for other advanced applications. See [Creating a Custom Sensor](#) ^[50] for more information.

HUNTER CLIK	
Rain Sensor (Normally Open)	A standard rain sensor (use this if you have wired the rain sensor's normally

	open wire to the controller)
Rain Sensor (Normally Closed)	A standard rain sensor (use this if you have wired the rain sensor's normally closed wire to the controller)
Soil Moisture Sensor (Normally Open)	A standard soil moisture sensor (use this if you have wired the soil moisture sensor's normally open wire to the controller)
Soil Moisture Sensor (Normally Closed)	A standard soil moisture sensor (use this if you have wired the soil moisture sensor's normally closed wire to the controller)

Wiring

Flow meters are supplied with [detailed installation instructions](#) ^[28].

The flow meter wires need to be cabled back to the controller and connected to the **Sensor** inputs on the controller. See chart below for wiring standard Hydrowise flow meters (Sizes include 3/4", 1", 1.5", 2")

FLOW METER WIRE	SCREW TERMINAL	CONTROLLER
BLUE	SEN 1, 2	HC
BLUE	SEN 1, 2	PRO-HC
BLUE	SEN	HPC-FP
WHITE	COM	HC
WHITE	SEN COM	PRO-HC
WHITE	SEN	HPC-FP
RED	Not Used, Cap off	N/A

SENSOR WIRE	SCREW TERMINAL	CONTROLLER
Wire 1	SEN 1, 2	HC
Wire 1	SEN 1, 2	PRO-HC
Wire 1	SEN	HPC-FP
Wire 2	COM	HC
Wire 2	SEN COM	PRO-HC
Wire 2	SEN	HPC-FP

WIRELESS RAIN CLIK	SCREW TERMINAL	CONTROLLER
--------------------	----------------	------------

Yellow/Yellow	24V/24V	HC
Yellow/Yellow	AC1/AC2	PRO-HC
Yellow/Yellow	AC1/AC2	HPC-FP
Blue	SEN 1, 2	HC
Blue	SEN 1, 2	PRO-HC
Blue	SEN	HPC-FP
White	COM	HC
White	SEN COM	PRO-HC
White	SEN	HPC-FP
Orange	Not Used for Hunter Controllers	Open Circuit Controllers Only

Once you've wired your rain, moisture sensor or flow meter, configure it in your Hydrowise account as shown below.

Sensor Configuration

There are two steps to getting your sensor to work for each of your zones:

1. Create a new sensor in your Hydrowise account under [Sensors](#) ^[46]. Choose the sensor name, type of sensor, and the controller input. You also have the option to [create a custom sensor](#) ^[50].
2. Once you've created your sensor, **assign the zones** that will use the sensor in the sensor table.

STEP 1

Add Sensor
✕

Sensor details
▸ Set zones

Sensor Name
 Assign a descriptive name for this sensor

Type of Sensor
 Choose the type of sensor you have installed. You can also create a custom sensor type if you have something non standard.

Controller Input
 Choose the input on the controller that this sensor is wired to

Cancel
< Prev
Next >
✔ OK

STEP 2

Add Sensor
✕

Sensor details
▸ Set zones

Select Zones

Select the zones which will use this sensor

Available zones

⇄

Selected zones

Cancel
< Prev
Next >
✔ OK

Create a Custom Sensor You can also create custom sensors in your Hydrowise account under **Sensors**. Some examples of custom sensor types are:

- A flow meter of a different size to the standard Hydrowise flow meters.

- A sensor to conform to restrictions that specify no watering for a minimum period of time after rain is detected.
- A sensor to start irrigation if motion is detected (Enthusiast Plan only)

To add a custom sensor type, go to **Sensors** and click on **Add Custom Sensor Type**. Give the sensor a name and choose its type as outlined below. **Flow Meter** Liters per pulse: The number of liters of water expected to pass through the flow sensor per flow meter pulse (you can get this information from your flow meter’s specifications) **Normally Open Sensor/Normally Closed Sensor** Sensor Action: Whether the sensor should cause a zone to start or stop. **Start a Zone** If the zone should start, choose the minimum number of seconds before the sensor can cause the same zone to start again. **Stop a Zone** If the zone should stop, choose the number of seconds to delay before stopping the zone, and how long the zone should be disabled. For example, some watering restrictions require that if rain is detected, sprinklers should not run for at least two days.

Custom Setup Example

Add Custom Sensor Type ✕

Sensor Type Name
Assign a descriptive name for this sensor definition

Type of Sensor

Normally Closed Sensor
▼

Sensor Action

Stop a zone
▼

Choose what happens when this sensor becomes active

Delay before stopping

hours
▼

Minimum number of seconds before stopping a running zone

Minimum off period

hours
▼

Minimum number of seconds the zone should be disabled for

Cancel
✔OK

Sensors - Clik Sensor Status

Please take note of the sensor states below once you've successfully set up your sensor through the Hydrowise application.

Normally Closed (Default Setup) All Hunter CLIK Sensors

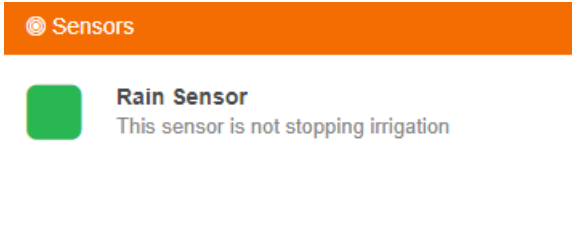
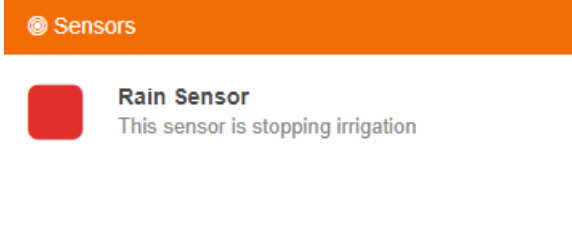
Sensor Status		
GREEN	Dry - Not Stopping Irrigation	Water
 <p>The screenshot shows a mobile application interface. At the top, there is an orange bar with a white circle containing a sensor icon and the word "Sensors". Below this, there is a green square icon followed by the text "Rain Sensor" and "This sensor is not stopping irrigation".</p>		
RED	Wet - Stopping Irrigation	No Water
 <p>The screenshot shows a mobile application interface. At the top, there is an orange bar with a white circle containing a sensor icon and the word "Sensors". Below this, there is a red square icon followed by the text "Rain Sensor" and "This sensor is stopping irrigation".</p>		

Note: A good example would be a simple switch where closed would represent **ON** position and open would mean the **OFF** position.

For more information on configuring sensors, check our guide [here](#) ^[51].

Sensors - Installing Personal Weather Station

Installing your own weather station

Installing your own weather station is not a requirement for using a Hydrowise controller. The vast majority of customers use one of the 25,000 weather stations already available to each Hydrowise controller. You may have already realized that the Hydrowise irrigation system is driven in part by temperature, rainfall measurements, and predictions sourced from a weather network called Weather Underground.

Worldwide, the network has tens of thousands of privately owned and operated weather stations that contribute data to be shared by all. During setup of your Hydrowise controller, you would normally select three or more nearby stations for temperature and rainfall calculations and decisions. Since Weather Underground is an open network, you have the option of setting up your own weather station to report and share weather data with others. It is relatively easy and inexpensive to do so.

There are a few possible reasons to set up your own station:

- You don't have any nearby stations to select from.
- You want your observations to be as accurate as possible.
- You have other uses for the local climate information.

There is a wide range of weather stations available on the market suitable for uploading weather data to Weather Underground. The following link provides the most common [Stations](#).^[52]

The different brands offer different measurements, accuracy, and build quality. Consequently, they vary in price from about \$100 (U.S. dollars) to \$1,000. They generally measure the following parameters:

- Indoor temperature and humidity
- Outdoor temperature and humidity
- Rainfall
- Wind speed
- Wind direction
- Atmospheric pressure

You can refer to this link for the exact steps to register your personal weather station. [Weather Underground](#)^[53]

Once Weather Underground has approved and are broadcasting the PWS, please provide us with the PWS ID. We can upgrade you to the free PWS plan so you have access to your own weather station. [Contact Us](#)^[54]

Master Valve - Configuration

A master valve is an automatic valve installed at the point where the irrigation system connects to the water supply. (Sometimes this circuit is called a “pump start circuit.” Both types work in a similar fashion, and can be used as a pump and/or a master valve.) The controller turns the master valve on and off.

How does it work?

Zone valves are the individual valves that operate a group of sprinklers or drip emitters. A Hydrawise controller supports 6 or 12 zone valves, depending on the model. Typically, one zone valve is turned on at a time and controls the irrigation in a specific area of your landscape. Whenever one of the irrigation zone valves is told to open by the controller, the controller also signals the master valve to open. This means that the master valve acts somewhat like a backup valve or a fail-safe valve. The purpose of the master valve is to shut off the water to the irrigation system when no zone valves are operating. The image below shows a master valve operating connected to Zone 12 on a Hydrawise controller.

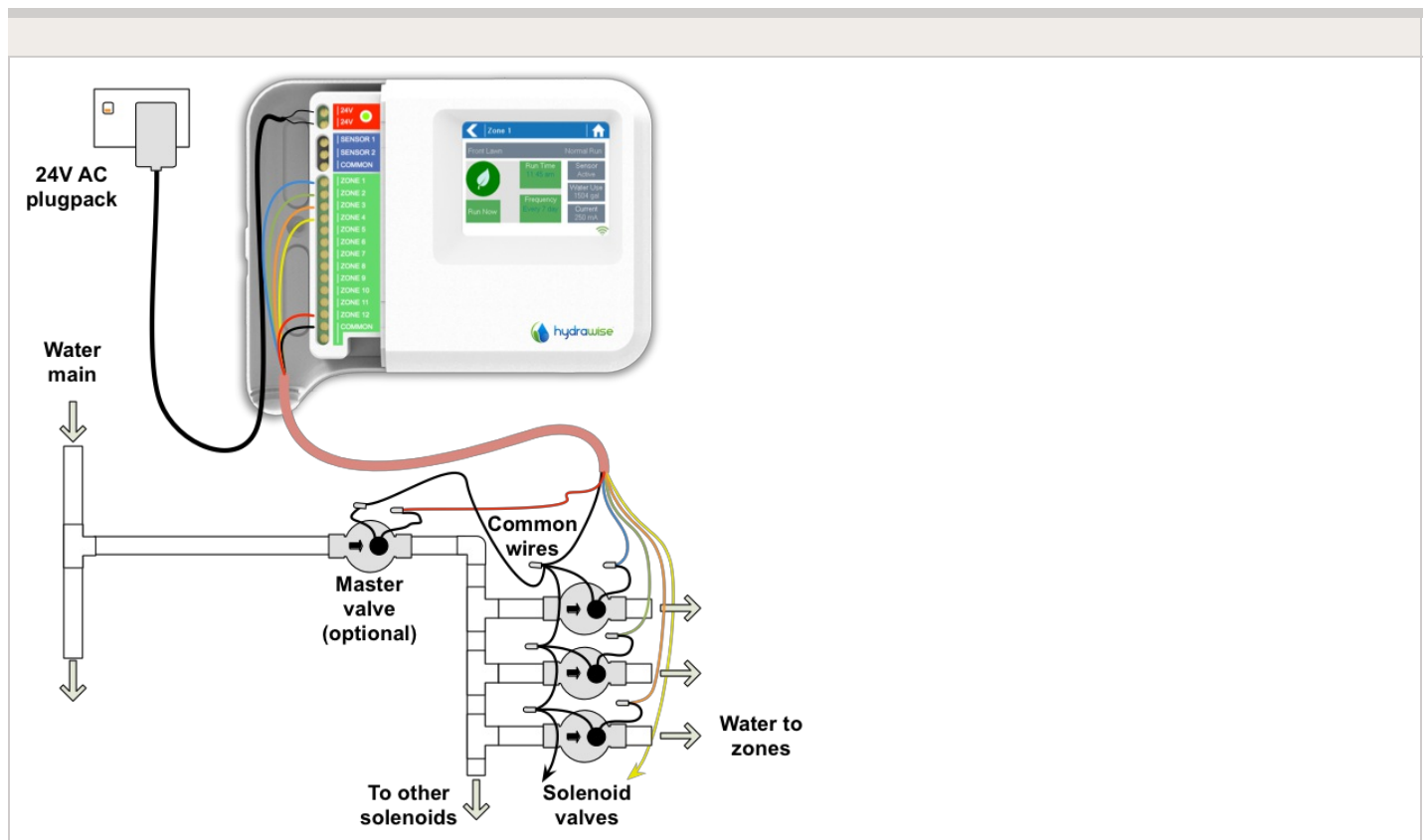

Master Valve - HC

With a Hydrowise controller, any one of your 6 or 12 zones can be configured to act as a master valve. The master zone is configured on the [Zones and Schedules](#) [55] page above your list of irrigation zones.

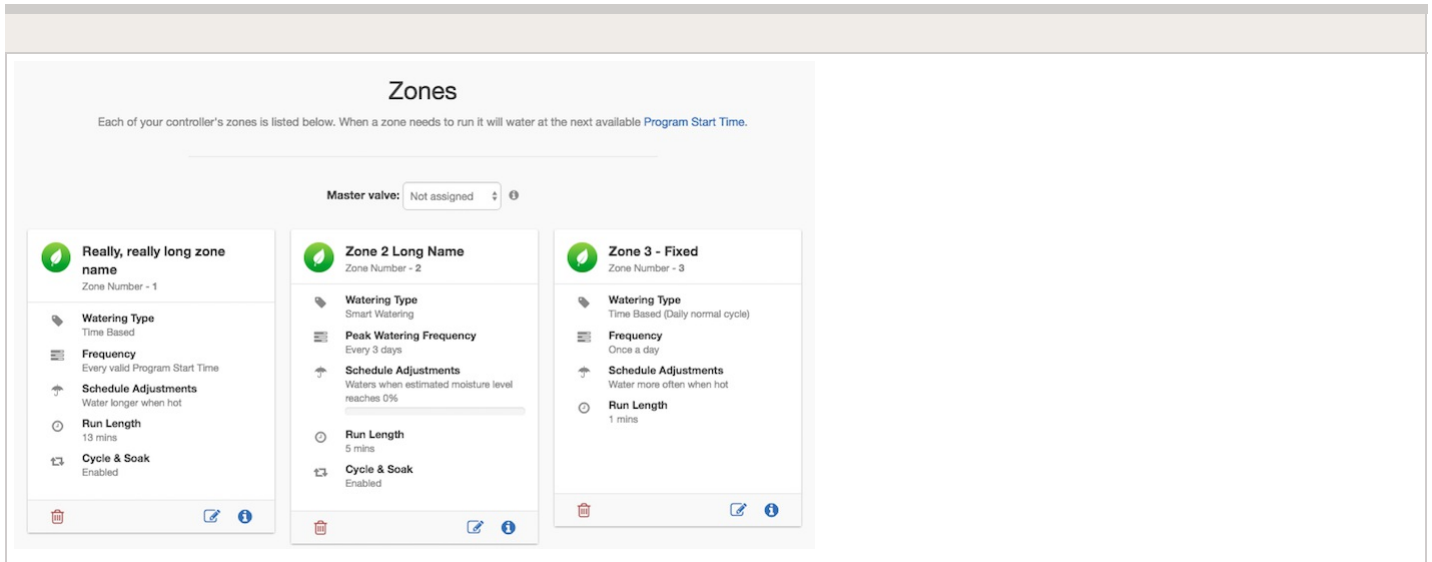

Initially, no master valve is configured and all zones on the controller can be used as normal zone valves. To select a master valve, select the relevant zone from the list next to the text that says **Master valve**.

Master Valve - PRO-HC

With the Pro-HC controller, setting the master valve (MV) is similar. If this was not set correctly in the setup wizard, you can access this from the **Zones and Schedules** section easily.

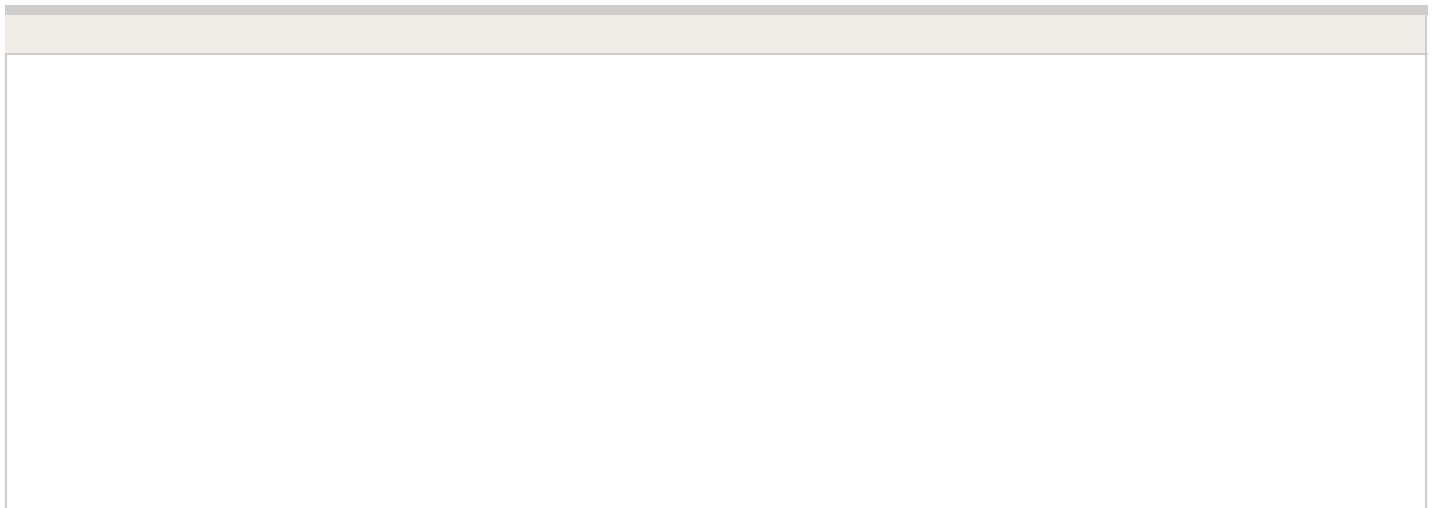

Zones

Each of your controller's zones is listed below. When a zone needs to run it will water at the next available Program Start Time

Master valve: Yes

You no longer have to select which zone the MV is connected to, as the option will be different depending on the controller you select when setting up your controller for the first time.

Master Valve - HPC-FP (Panel for PC-400 controller)

The default is for all stations to have the master valve/pump start circuit ON. The master valve/pump start can be set **ON** or **OFF** by station, regardless of which program the station is assigned.

First, make sure you have the master valve selected "YES" in the box below:

Next, follow the steps for initializing the P/MV for each zone.

1. Click the  icon for the zone in **"zones and schedules"**
2. Click **Next** three times to enter the advanced section or programming.
3. You can now choose either of the following:
 1. Use **Global Master Valve Setting** (Turns the P/MV circuit ON)
 2. Use **Disable Master Valve** (Turns the P/MV circuit OFF)

MASTER VALVE

Use Global Master Valve Setting Disable Master Valve

WATERING ADJUSTMENT

Fine tune your watering if your zone appears to be too dry or wet



Cancel

< Prev

Next >

OK

Valve - Wire Distance

Below is a chart indicating the maximum wire run between the controller and the Hunter AC solenoid valves.

Valve Wire Sizing (Feet)							
Ground	Control Wire						
	18	16	14	12	10	8	6
18	850	1040	1210	1350	1460	1540	1590
16	1040	1340	1650	1920	2150	2330	2440
14	1210	1650	2150	2630	3080	3450	3700
12	1350	1920	2630	3390	4170	4880	5400
10	1460	2150	3080	4170	5400	6670	7650
8	1540	2330	3450	4880	6670	8700	10530
6	1590	2440	3700	5400	7690	10530	13330

Notes:

Maximum one-way distance in feet between controller and valve heavy-duty solenoid: 24 VAC, 350 mA inrush current, 190 mA holding current, 60 Hz; 370 mA inrush current, 210 mA holding current, 50 Hz

Valve Wire Sizing (Metric)							
----------------------------	--	--	--	--	--	--	--

Ground	Control Wire					
	0.5	1	1.5	2.5	4	6
0.5	140	190	210	235	250	260
1.0	190	290	335	415	465	495
1.5	208	335	397	515	595	647
2.5	235	415	515	730	900	1030
4.0	250	465	595	900	1175	1405
6.0	260	495	647	1030	1405	1745

Notes:

Maximum one-way distance in meters between controller and valve Heavy-duty solenoid:

24 VAC,

350 mA inrush current, 190 mA holding current, 60 Hz; 370 mA inrush current, 210 mA

holding current, 50 Hz